

SuperH[®] Family of Microcontrollers and Microprocessors

#1

Renesas is the
World's largest
MCU supplier
with over
20% market
share

- **One of the world's leading ITDM (Integrated Device and Technology Manufacturer) companies serving the global market**
- **In-house manufacturing capability for advanced process nodes –90, 65 and 45 nm**
- **Complete System-Level Solutions** — Solutions in all core segments (automotive, mobile, consumer, industrial and PCs) with the right mix of technology such as networking (wired/wireless), security, low power and analog/RF interface capabilities; plus full-scale development support
- **Proven credibility based on more than 30 years of experience**
 - “Zero Defects” as the objective
 - Compliance with international standards such as ISO/TS 16949
 - High quality tested and proven by customers
 - Commitment to safety and protection of environment

Renesas — Your Best Decision for Microcontrollers and Microprocessors

Choose for your next design; use for all your future ones.

Renesas Technology, the #1 global supplier of microcontrollers, offers hundreds of devices in our M16C™, H8®, and SuperH® families, among others, that have solid technology roadmaps and cover wide spans of performance, integration, power efficiency and price points. Our advanced silicon solutions simplify system optimizations, facilitate design enhancements and diversifications, and help you meet tight cost budgets. You can shorten your system design cycles and improve your time-to-market by taking advantage of our total system support, which includes starter kits, HW/SW tools, reference designs/platforms, example software code, and middleware. Expert third-party support is available as well.



LEAD-FREE PACKAGING!

FOR THE LATEST INFORMATION ON LEAD-FREE PACKAGING AND ROHS COMPLIANCE,
PLEASE VISIT OUR WEBSITE: <http://america.renesas.com/leadfree>

LET “MY RENESAS” SIMPLIFY YOUR WEB-BROWSING ACTIVITY

The “My Renesas” link in the header of all of our Web pages is a valuable and easily accessible resource. It lets you create a customized collection of links and data that simplifies and speeds your browsing.

Get timely updates on Renesas products, receive our latest news stories, and be alerted to software downloads and new web services as they become available. Register today to facilitate future data searches.

IMPORTANT!

- This document may, wholly or partially, be subject to change without notice.
- All rights are reserved: No one is permitted to reproduce or duplicate, in any form, the whole or part of this document without the express permission of Renesas Technology America, Inc.
- Renesas will not be held responsible for any damage to the user that may result from accidents or any other reasons during the operation of the user's unit according to this document.
- Circuitry and other examples described herein are meant merely to indicate the characteristics and performance of Renesas semiconductor products. Renesas assumes no responsibility for any intellectual property claims or other problems that may result from applications based on the examples described herein.
- No license is granted by implication or otherwise under any patents or other rights of any third party or Renesas Technology Corp.
- **MEDICAL APPLICATIONS:**

Renesas products are not authorized for use in MEDICAL APPLICATIONS without the written consent of the appropriate officer of Renesas' sales company. Such use includes, but is not limited to, use in life support systems. Buyers of Renesas products are requested to notify the relevant Renesas sales officers when planning to use the products in MEDICAL APPLICATIONS.

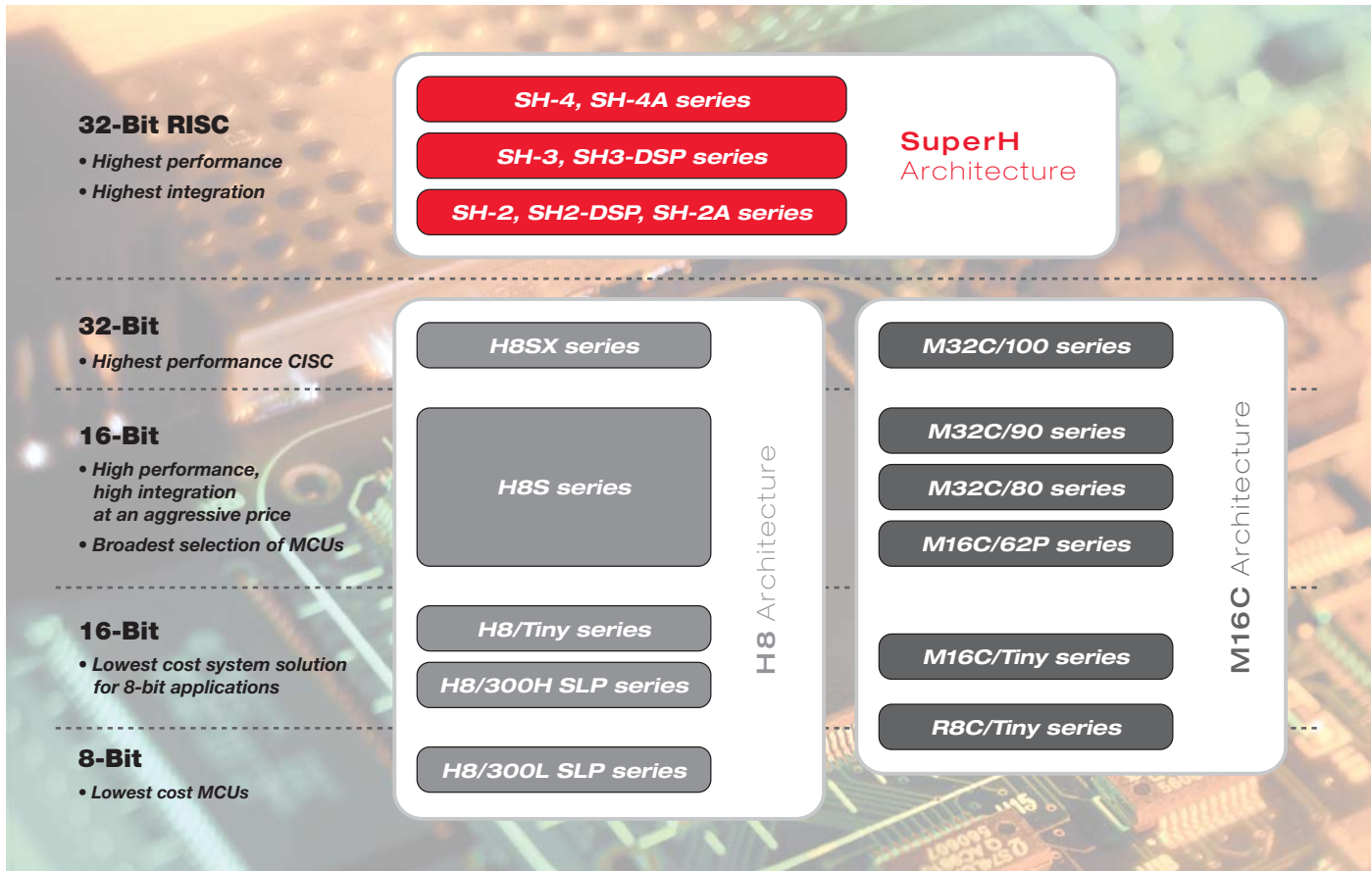

Market Needs	SuperH Solutions
Performance	Up to 1080 MIPS, 4.2 GFLOPS (SH-4A); up to 360 MIPS (SH-2A), superscalar architecture
Cost/performance	High MIPS/\$ ratings
Power/performance	High MIPS/W ratings
Code efficiency	16-bit instructions: up to 40% smaller memory footprint, up to 40% more data in cache
Flash ROM	Up to 1MB flash, accessible in one cycle at 80MHz; single-voltage programmable
Floating-point and DSP support	DSP (SH2-DSP, SH3-DSP), superscalar FPU (SH-2A, SH-4, SH-4A), Superscalar DSP (SH-Mobile)
Graphics support	Superscalar operation [FPU operations independent of non-FPU operations] (SH-2A, SH-4, SH-4A) 2D and 3D graphics engine (SH-Mobile)
Video and Imaging	H.264, MPEG4, H.263, and JPEG engines
On-chip peripherals	Timers, DSP, MMU, A/D, D/A, memory controller, LCD controller, AFE, motor controller, cache, BSC, crypto accelerator, more
Industry-standard interfaces	USB, Ethernet, PCI, SCI, I ² C, PCMCIA, SSI (Audio), CAN, Smart Card, IrDA, SDRAM, DDR-SDRAM, NAND flash, memory card, camera
Architecture roadmap	Instruction set accommodates superscalar designs
Code compatibility	Upward compatible families (SH-1, SH-2, SH-3, SH-4)
Power consumption	Low static/dynamic operating currents, high MIPS/W ratings, power-down modes
Development environment	Comprehensive integrated H/W and S/W tools, extensive third-party support, on-chip debug
Off-the-shelf solutions	Middleware, reference boards, broad OS support
Support and training	Experienced application engineers, online evaluation lab, training courses

The SuperH Family Roadmap

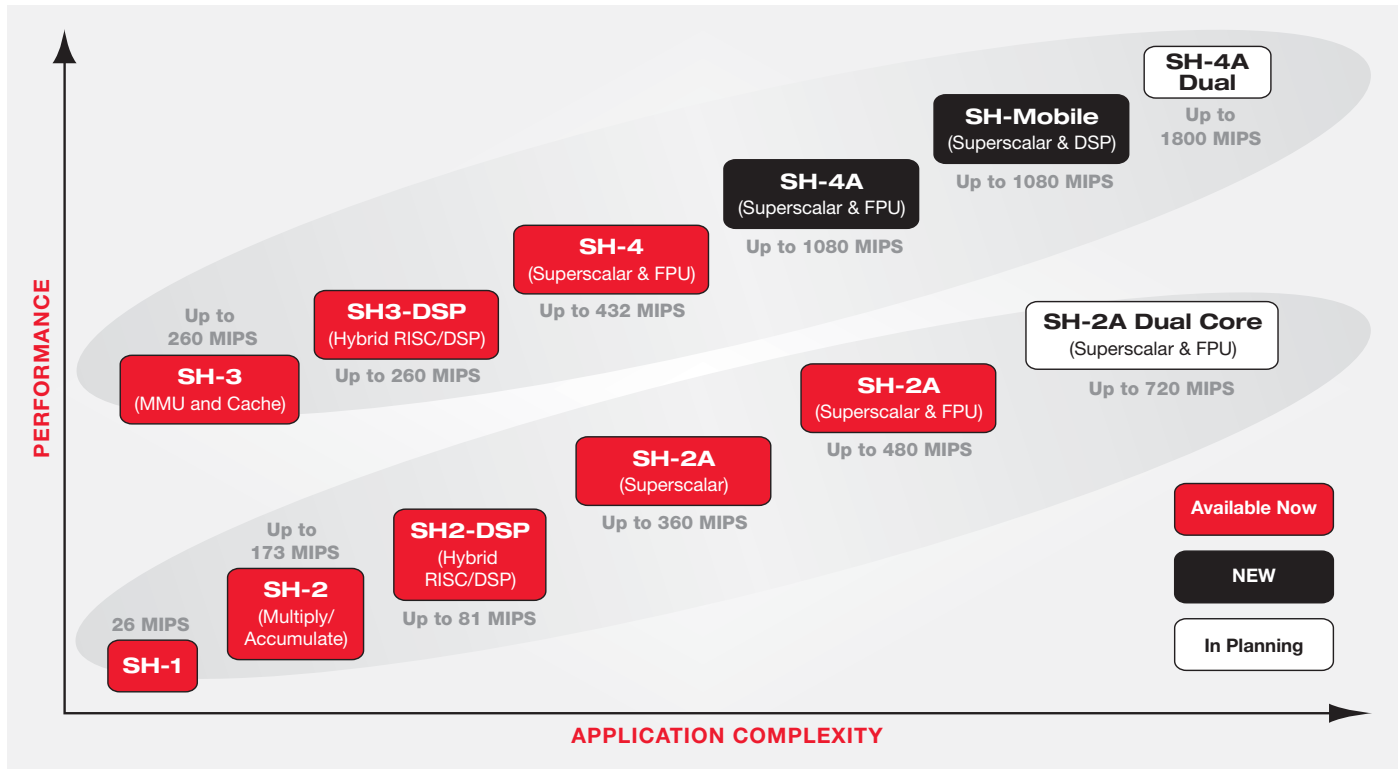

The first 32-bit SuperH RISC device was introduced in 1993. In the years since, this popular product line has continuously grown and steadily evolved. Today it encompasses ten major product families, with more in development. They continue a solid technology roadmap of innovation fine-tuned to meet the changing needs of designers of embedded systems for diverse global markets.

A steadfast goal throughout the history of the SuperH family has been to produce microcomputers [microcontrollers (MCUs) and microprocessors (MPUs)] that deliver optimum mixes of performance and functionality, achieve requisite levels of performance at low power, and have compact packages. We also work to ensure that SuperH devices are offered at competitive prices and are supported by a comprehensive suite of Renesas hardware and software development tools. Importantly, we maintain code compatibility throughout the product line to facilitate software reuse that saves development time and engineering cost.

Renesas offers SuperH MCUs for general-purpose applications and SuperH MPUs for specialized applications. The MCUs in our **SH-1**, **SH-2**, **SH2-DSP**, and **SH-2A** series for general-purpose embedded system use offer CPU performance up to 480 MIPS and have reliable, high-capacity flash memory that is easy to use and simplifies system designs. The MPUs in our **SH-3**, **SH3-DSP**, **SH-4**, and **SH-4A** series for specialized applications deliver performance levels up to 1080 MIPS and provide on-chip peripherals tailored for leading-edge applications in automotive, mobile, and PC/AV markets, among others. Support for SuperH MCUs and MPUs is comprehensive, encompassing development tools, operating systems, drivers, middleware, and other products and services from Renesas and a large international community of technology partners and third-party vendors. This support facilitates the rapid development of SuperH-based products and solutions.

Renesas **SH-Mobile** application processors are used in tens of millions of mobile phones for offloading the processing of multimedia content from the main CPU. This baseband-independent design approach facilitates the rapid evolution of cell phones and other portable devices that can handle innovative new communication services and features without impacting the implementation of proven protocol processing methods. Beyond those markets, highly versatile SH-Mobile devices suit an expanding array of products that require smooth audio/video capture and playback, fast processing for software stacks, flexible connectivity options, and small form factors.

SH-Mobile devices perform master or co-processor roles, or both. All have powerful superscalar **SH4A-DSP** cores that readily handle JPEG, MPEG-1 Audio Layer 3 (MP3), and MPEG-4 data. The chips also provide extensive peripheral functions. For example, a built-in H.264 video engine achieves a 200% performance increase on average for most middleware, allowing reductions in CPU speed and power consumption.

Renesas supports SH-Mobile multimedia application processors with system development platforms, HW/SW tools and other resources. Additionally, the 200+ members of the SH-Mobile Consortium from around the world offer middleware, operating systems, board support packages, system integration assistance, and application support. Their technologies and services help speed time-to-market for complete system designs.

The SuperH family of MCUs and MPUs serve a wide range of embedded systems. The table on the next page summarizes key applications of each device series.

SuperH Series Performance, Features and Applications

Core	CPU/Bus Speed	Performance	Series	Features / Remarks	Key Applications
SH-2	80/40MHz	104 MIPS	SH7080 SH7040 SH7140	High-performance embedded controller with integrated RAM/cache/ROM/flash and advanced motor control timers	AC/DC drives, inverters, servo/motion controllers, machine tools
	50/40MHz	65 MIPS	SH7125	SH/Tiny series; compact package	
	133/66MHz	173 MIPS	SH7600	SH-Ether series; integrated Ethernet, host interface	Industrial control, networking
SH2-DSP	62.5/31.25MHz	81 MIPS/ 125 MOPS	SH7065 SH7600	Combined RISC/DSP architecture; derivatives with integrated Ethernet and PWM timers	Industrial control, networking, office automation
SH-2A	200/66MHz	480 MIPS	SH7200	High performance, superscalar, optional FPU, fast interrupt response time	Industrial control, office automation, multimedia
SH-3	200/66MHz	260 MIPS	SH7700	Low-power consumption, high-speed, MMU, cache, SDRAM I/F, PCMCIA	Office appliances, bar code scanners, digital still cameras
SH3-DSP	200/66MHz	260 MIPS/ 400 MOPS	SH7729R SH7727 SH7720 SH7710	Combined RISC/DSP architecture; pin-compatible to some SH-3 derivatives, other features similar to SH-3 devices	Handheld/portable devices, routers, cable modems, postage meters, multimedia, web phones
SH-4	240/120MHz	432 MIPS 1.7 GFLOPS	SH7750R SH7751R SH7760	High performance, superscalar, FPU, vector graphic operations, MMU, SDRAM I/F, PCMCIA, etc.	CIS/Telematics, video game consoles, sub-note books, set-top boxes, residential gateways, etc.
SH-4A	600/300MHz	1080 MIPS 4.2GFLOPS	SH7780 SH7785 SH7763	High performance, superscalar, FPU, vector graphic operations, SuperHyway bus, MMU, DDR-SDRAM interface	CIS/Telematics, home multimedia, entertainment, gateways
SH4A-DSP	400/133MHz	720 MIPS 800 MOPS	SH-Mobile	High-performance, superscalar, DSP, video/imaging/graphics engines, SuperHyway bus, MMU	Portable multimedia players, digital TV, video phones, IP cameras

A Global Leading Position

Renesas Technology has acquired an impressive reputation for leadership and earned a large share of the embedded processor market in leading-edge growth areas of automotive and mobile applications. For example, through SuperH devices incorporating an SH-4 or SH-4A CPU core, we have gained about an 80% worldwide share of the microcontrollers used in car navigation systems. And our SH-Mobile family is the de facto standard in application processors for mobile phones, being used in over 200 different models. As we expand the SuperH family, we are applying the advanced technology acquired in those fields together with Renesas' long-term commitment for product availability to other markets that have technology and application challenges, such as industrial control and office automation. Techniques for obtaining improved power efficiency have wide appeal, as do on-chip peripherals and high code density. The SuperH family of MCUs and MPUs continues to be the architecture of choice for embedded system designers.



■ SuperH Architecture: Common Features

RISC-type instruction set

- Instruction length: fixed 16-bit-long instructions for improved code efficiency
- Load-store architecture (basic arithmetic and logic operations are carried out between registers)
- Delayed unconditional branch instructions reduce pipeline disruption
- Instruction set optimized for the C language

CPU register set

- Sixteen 32-bit general-purpose registers
- Up to 7 control registers and 4 system registers for fast jumps and interrupt response

Efficient caching scheme for each series

- LRU replacement policy algorithm for improved hit rates
- Each family's cache architecture has been optimized for the best latency/miss-rate balance: e.g., SH-4A devices have 32KB + 32KB, 4-way set-associative, separate instruction and operand caches for improved performance

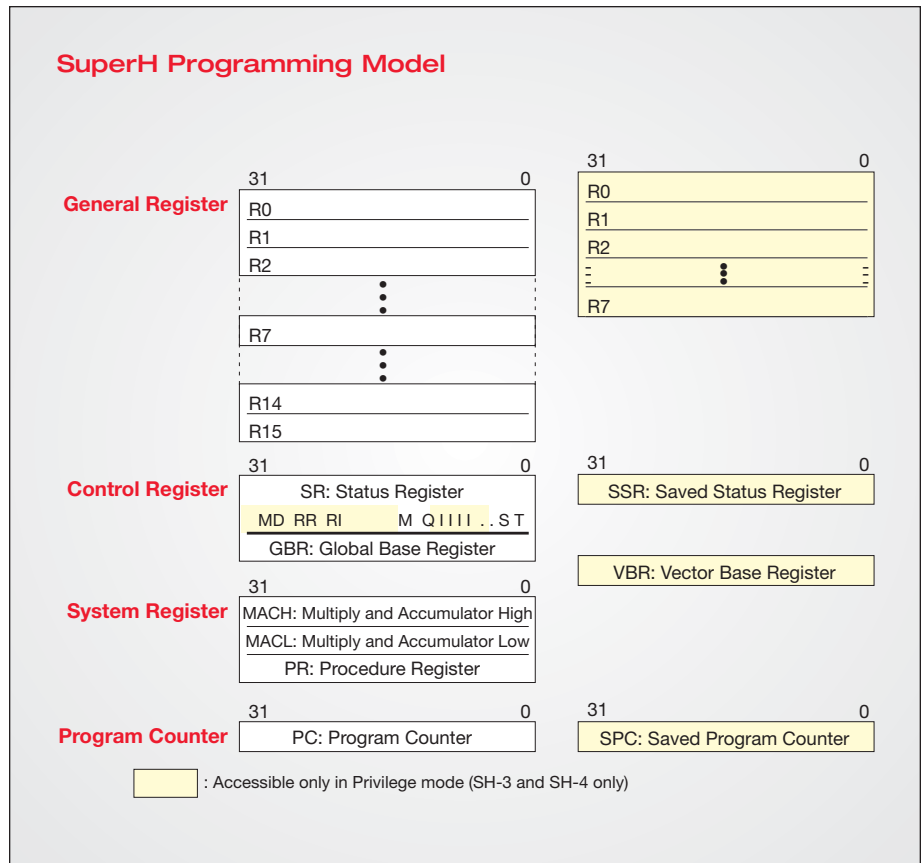
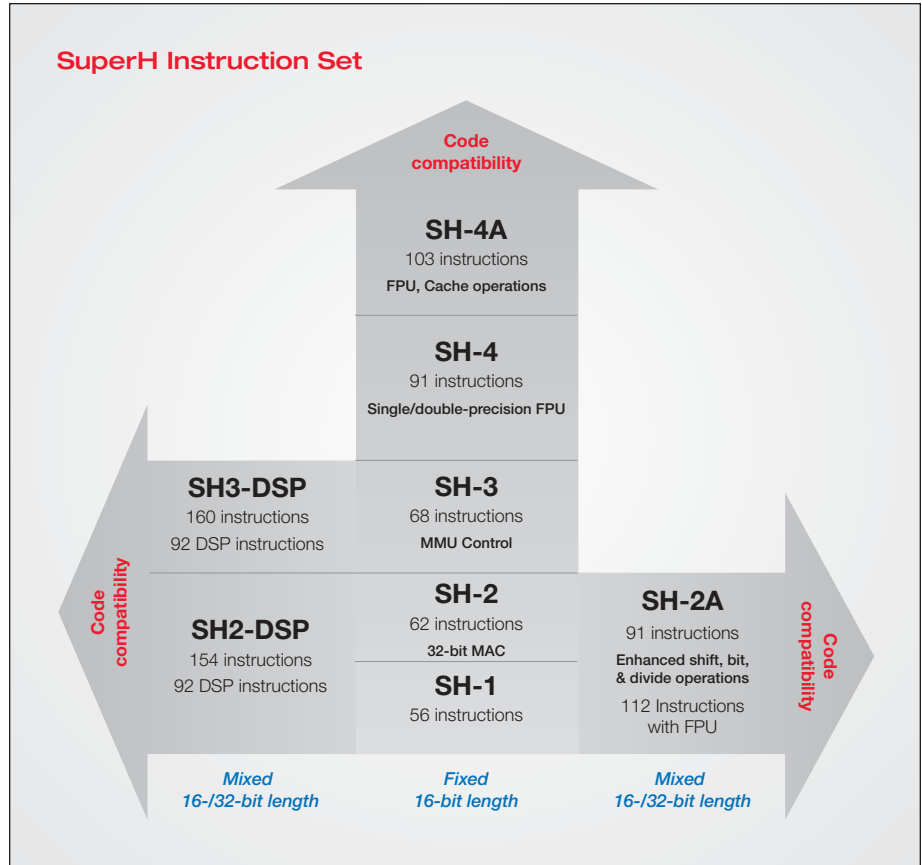

Built in hardware multiply-accumulate unit

- 16-bit x 16-bit + 42-bit (SH-1 devices)
- 32-bit x 32-bit + 64-bit (SH-2, SH-3, SH-4 chips)

Instruction execution

- Scalar architecture:
One instruction per clock cycle
- Superscalar architecture (SH-2A/SH-4/SH-4A onwards):
Maximum of two instructions per cycle
- 5-stage instruction pipeline (7-stage in SH-4A)

Memory Management Unit for RTOS (SH-3 and beyond)

- 4-Gbyte address space,
256 address space identifiers (8-bit ASIDs)
- Single virtual mode and multiple virtual memory mode
- Supports multiple page sizes: 1KB, 4KB, 64KB, 1MB
- 4-entry fully-associative TLB for instructions
- 64-entry fully-associative TLB for instructions and operands
- Supports software-controlled replacement and random-counter replacement algorithm
- TLB contents can be accessed directly by address mapping

SH-2A/SH-4/SH-4A Two-Way Superscalar Architecture

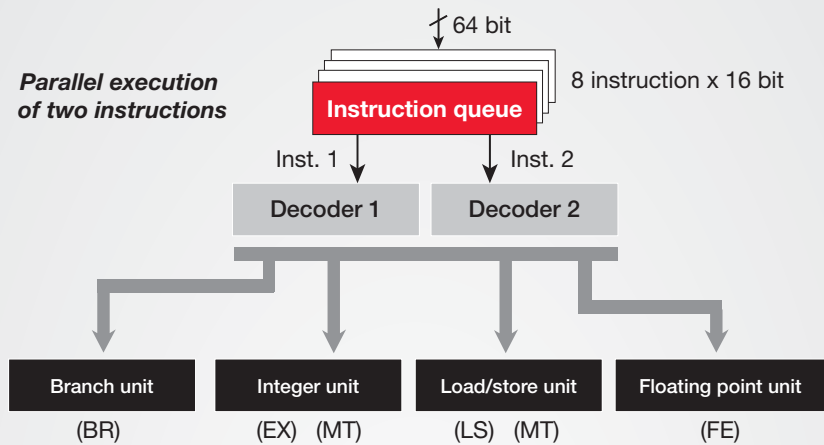

Superscalar Operations

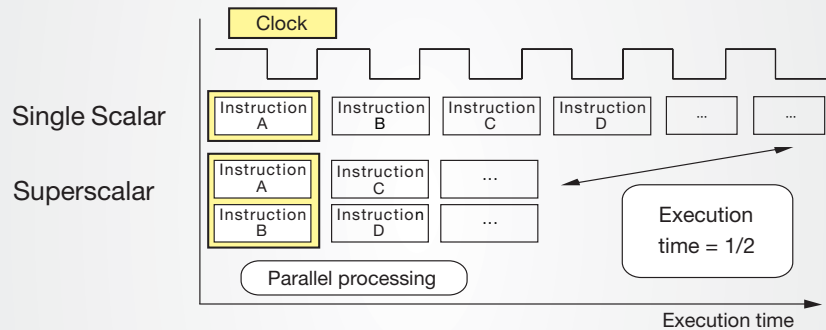

MMU Block Diagram

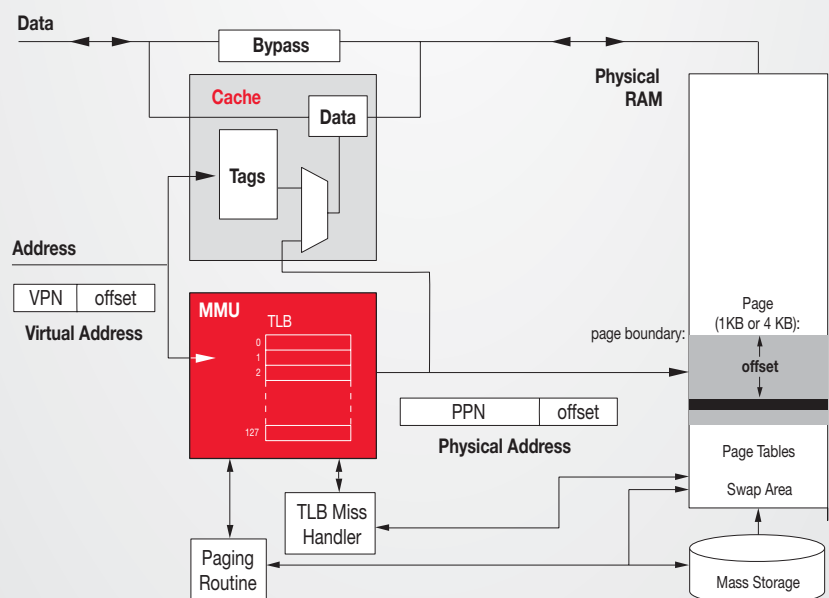

■ SH-2A Family Features

Instruction set upward compatible with SuperH RISC Family

- Upward compatible with SH-1 and SH-2 Family of devices
- Compact 16/32-bit instruction code
- Flexible addressing modes.

Integrated SH-2A CPU engine and FPU optimized for performance, low power and cost

- Improved performance
 - 1.5x performance compared to SH-2 architecture
- Better code density
 - 75% code-size reduction compared to SH-2 core
- Real-time control
 - 6-cycle interrupt-response time
- Floating Point Unit (FPU):
 - 1.4 GFlops performance

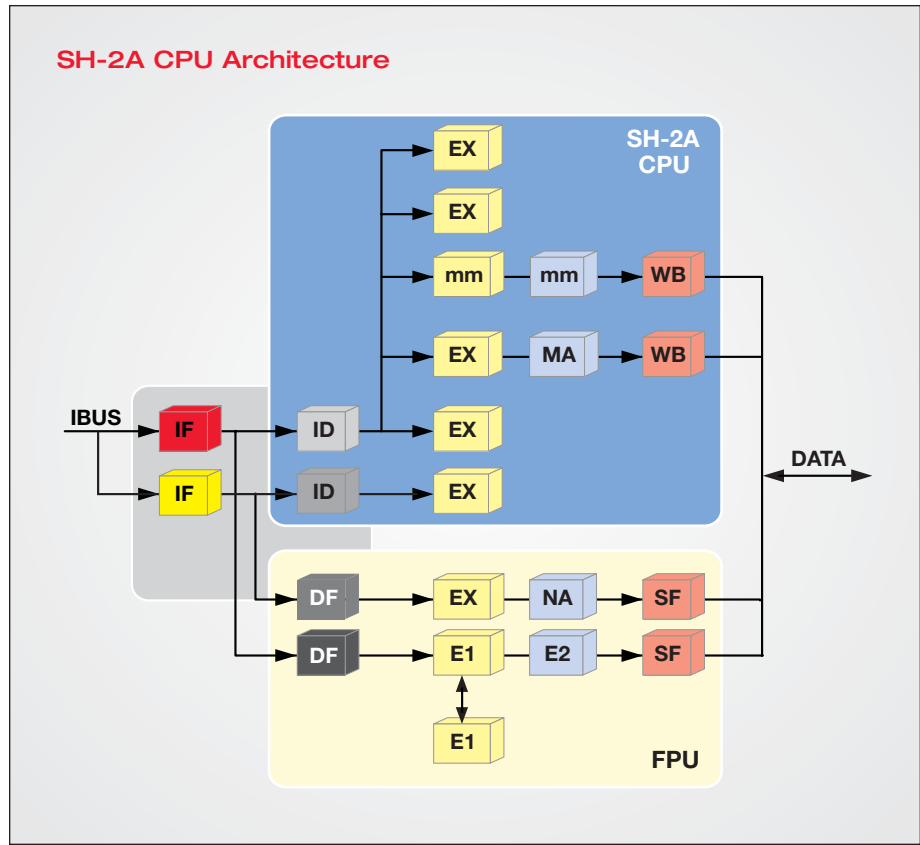

SH-2A CPU Architecture

- Superscalar RISC engine
- 32-bit Harvard architecture
- 5-stage RISC CPU pipeline
- Instruction/Data cache
- 2-instruction/cycle execution time
- Conditional delayed branching
- Flexible addressing modes
- On-chip multiplier unit supports MAC operations
- Prioritized exception handling

SH-2A FPU Architecture

- Supports IEEE-754 compliant data types and exceptions
- Independent 5-stage pipeline
- Single/double-precision operation support
- 16 x 32-bit floating point registers
- Supports FMAC/FDIV/FMUL/FSQRT instructions

Abundant Registers

- 16 x 32-bit general-purpose
 - R0 - R15
- 4 x 32-bit system registers
 - (MACH/L) High/Low Multiply & Accumulate registers
 - (PR) Procedure register
 - (PC) Program counter register
- 4 x 32-bit control registers
 - (SR) Status register
 - (GBR) Global base register
 - (VBR) Vector base register
 - (TBR) Jump-table base register
- 16 x 32-bit Floating Point Registers
 - FPR0 - FPR15
- Register banks
 - Allow contents of general registers R0 to R14, global register (GBR), the multiply and accumulate registers (MACH, MACL), the procedure register (PR), and the interrupt vector table address offsets (VTO) to be banked during interrupts

Improved Instruction Set

- 16-bit basic instructions for improved efficiency
- 32-bit instructions for improved performance
- Delayed branch instructions.
- Register bank instructions for improved interrupt latency
- Barrel shift instructions supporting logical and arithmetic operations
- Multiple register save/restore instructions
- Instruction set based on C language for ease of development

Easier to program; simplified product development

- Multitasking instead of multiprocessing
- Eliminates inter-processor communication
- Single hardware/software design environment

■ SuperH On-Chip Floating Point Co-processor Architectural Features

- Supports single-precision (32 bits) and double-precision (64 bits)
- 10-stage floating instruction pipeline (SH-4A)
- Supports IEEE754-compliant data types and exceptions
- Floating-point registers: 32 bits x 16 words x 2 banks
- (Single-precision x 16 words, or double-precision x 8 words) x 2 banks
- 32-bit CPU-FPU floating-point communication register (FPUL)
- Supports FMAC (multiply-and-accumulate) instruction
- Supports FDIV (divide) and FSQRT (square root) instructions
- Supports FLDI0/FLDI1 (load constant 0/1) instructions
- 3D graphics instructions (single-precision only)
- 4-dimensional vector conversion and matrix operations (FTRV): 4 cycles (pitch), 8 cycles (latency)
- 4-dimensional vector (FIPR) inner product: 1 cycle (pitch), 5 cycles (latency)
- Instruction execution times
 - Latency (FMAC/FADD/FSUB/FMUL): 3 cycles (single-precision), 8 cycles (double-precision)
 - Pitch (FMAC/FADD/FSUB/FMUL): 1 cycle (single-precision), 6 cycles (double-precision)

128-bit Floating Point Vector Engine: DSP/SIMD Instructions

16-tap, 40-sample block FIR (1.6 MACs/cycle)

$$\begin{array}{c} \mathbf{Y}_i \\ \mathbf{Y}_{i+1} \\ \mathbf{Y}_{i+2} \\ \mathbf{Y}_{i+3} \end{array} = \begin{array}{c} X_i \quad X_{i+1} \quad X_{i-2} \quad X_{i-3} \\ X_{i+1} \quad X_i \quad X_{i-1} \quad X_{i-2} \\ X_{i+2} \quad X_{i+1} \quad X_i \quad X_{i-1} \\ X_{i+3} \quad X_{i+2} \quad X_{i+1} \quad X_i \end{array} \times \begin{array}{c} c0 \\ c1 \\ c2 \\ c3 \end{array} + \dots + \begin{array}{c} X_{i-12} \quad X_{i-13} \quad X_{i-14} \quad X_{i-15} \\ X_{i-11} \quad X_{i-12} \quad X_{i-13} \quad X_{i-14} \\ X_{i-10} \quad X_{i-11} \quad X_{i-12} \quad X_{i-13} \\ X_{i-9} \quad X_{i-10} \quad X_{i-11} \quad X_{i-12} \end{array} \times \begin{array}{c} c12 \\ c13 \\ c14 \\ c15 \end{array}$$

1024-point, radix-2 FFT (35.4 cycles)

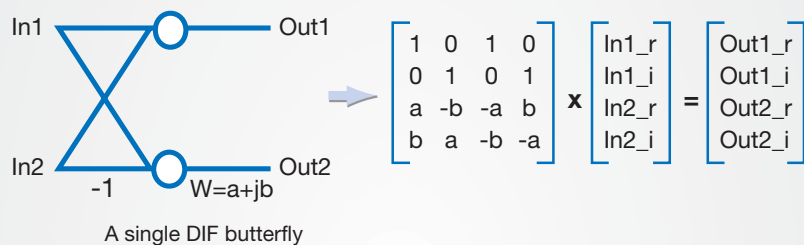

Versatility of the floating point co-processor

MULTIPLICATION

Multiplication 3-D graphics geometry

$$\begin{array}{c} Y1 \\ Y2 \\ Y3 \\ 1 \end{array} = \begin{array}{c} c11 \quad c12 \quad c13 \quad c14 \\ c21 \quad c22 \quad c23 \quad c24 \\ c31 \quad c32 \quad c33 \quad c34 \\ c41 \quad c42 \quad c43 \quad c44 \end{array} \times \begin{array}{c} x1 \\ x2 \\ x3 \\ 1 \end{array}$$

A single SuperH instruction, FTRV, can perform this matrix-vector multiplication every 4 cycles.

INNER PRODUCT

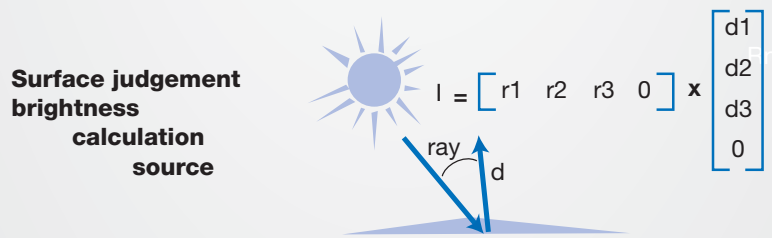

A single SuperH instruction, FIPR, can perform this inner-product multiplication every cycle.

Powerful 4-way FPU for 3-D graphics

SH-2A Enhancements

Higher Execution Performance

- Superscalar gives **1.5x** more performance at the same MHz
- SH-2A = **6x** the performance of SH-2

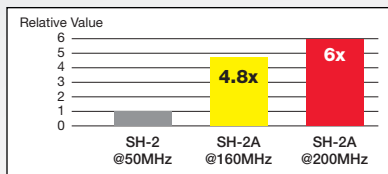

Faster Interrupt Response Time

- SH-2: 37 cycles;
- SH-2A: 6 cycles
- SH-2A = **1/25x** the response time of SH-2

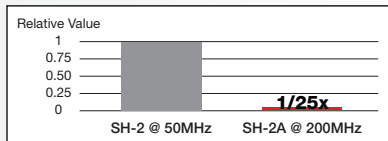

Denser Program Code Size

- Improved C compiler and additions to instruction set provide **25%** code size reduction

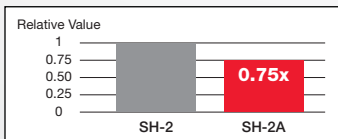

SH-4A Enhancements

	SH-4A	SH-4
Higher Performance at Lower Power	600 MHz @ 1.25V	240 MHz @ 1.5V
Improved Micro-Architecture	Superscalar 7-Stage Pipeline	Superscalar 5-Stage Pipeline
Improved FPU Architecture	10-Stage Pipeline	5-Stage Pipeline
Larger Cache Size	32/32 KB I/O Cache 4-Way Set-Associative	16/32 KB I/O Cache 2-Way Set-Associative
Greater Bandwidth Bus Architecture	SuperHyway 3 Independent Buses	Shared Bus
Instruction Set Architecture	103 Instructions	91 Instructions

TOP REASONS TO SELECT SuperH

Upward Code Compatibility

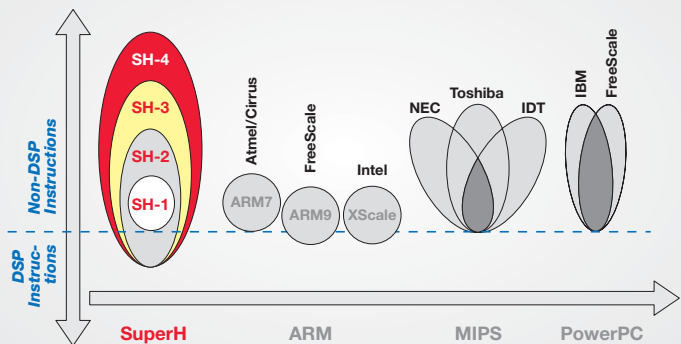

Total upward code compatibility

The roadmap for the SuperH processor product line is upwardly code compatible. This compatibility enables a faster time-to-market with further amortization of prior engineering investment and preservation of previously written software.

- Processor choice from 10 to 1080 MIPS
- Large selection of devices within each family

Best code efficiency

- 16-bit instruction length for high code density
- Up to 40% less memory footprint than 32-bit instructions
- Up to 40% more data in cache than 32-bit instructions
- Twice the number of instructions loaded on the SDRAM bus

SuperH Code Efficiency

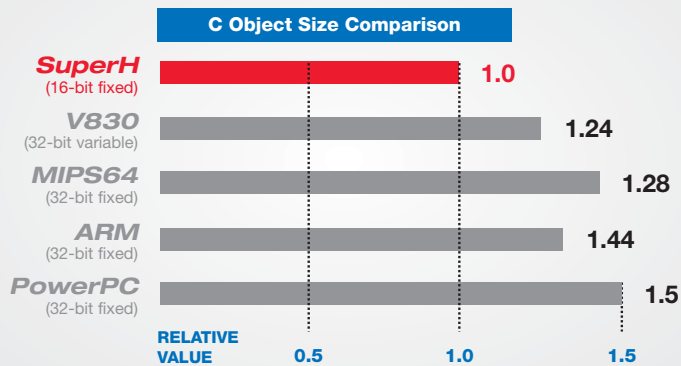

TOP REASONS TO SELECT SuperH

■ Balanced power/performance

The fast speeds that SuperH devices provide would not be usable by portable applications if the chips' power dissipation was excessive. Therefore, Renesas has designed the RISC and RISC/DSP devices in low-power sub-micron CMOS processes with low-voltage capabilities. Low static operating current is achieved in all circuit designs; low dynamic (peak) currents are guaranteed by logic and circuit design.

- Power-reducing techniques used in cache design
 - The sense amplifiers utilize SRAM circuit-design techniques that reduce word-line voltage swings; this permits lower currents to be used without sacrificing speed
 - A unique cache-way-enable circuit minimizes power demands by turning on the sense amplifiers only in that portion of the cache that has a “hit” in a given access; this reduces the cache data array's operating current by 75%
- Software-controlled power-reduction mechanisms:
 - Each device family offers a selection of power-reduction techniques from a palette that includes Standby and Sleep modes, clock-speed control and selective module shutdown
 - Low operating and standby currents for longer battery life.
- Hardware acceleration further reduces power consumption
 - Video, imaging, graphics, and security engines significantly improve computational speeds while minimizing power consumption

■ High integration

Renesas meets the dual needs for compact devices and low system cost by providing a broad choice of on-chip memories and peripherals in the SuperH series.

- Large size and high performance on-chip memory: Up to 1MB on-chip flash memory, up to 128KB on-chip RAM, and up to 32KB instruction and 32KB data cache
- 4- to 12-channel DMAC, 2 to 5 SCIs, 16-bit and 32-bit timers (3 to 34 channels), up to 149 I/O ports, RTC, analog interfaces (4 to 32 channels), I²C, CAN (up to 2 channels), others

- All SuperH-series processors feature direct interfaces to external memories. The on-chip Bus State Controller, via the external bus, provides the specialized inputs, outputs and functions for different types, widths, and speeds of external memory (8/16/32-bit interfaces to DRAM, SDRAM, DDR-SDRAM, flash, ROM, etc.)

■ Best cost/performance

The SuperH architecture has a superior performance-to-price ratio (Dhrystone MIPS/\$). The architecture's 16-bit RISC instruction set reduces system memory requirements, which lowers the overall cost of embedded system designs.

■ Superior floating point and DSP support

- The SuperH Family of processors with Floating Point Unit (SH-2A, SH-4, SH-4A) and DSP (SH2-DSP, SH3-DSP, SH-Mobile) support allow users to achieve more with less, reducing overall system cost and power consumption
- The SH-4 FPU is ideal for computer graphics and can be utilized to efficiently implement multimedia and networking operations

SH2-DSP Signal Processing Performance

JPEG image compression/expansion processing performance:

- 10 times higher than SH-1
- 3 times higher than SH-3

JPEG compression processing time (in seconds)

0 1 2 3 4 5

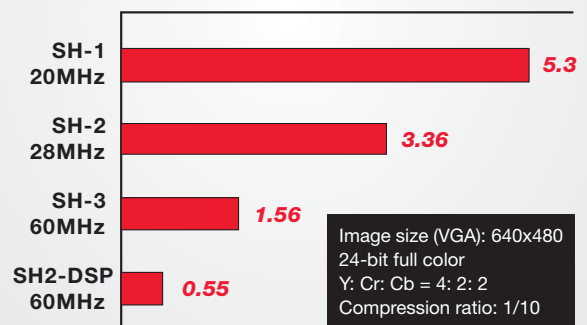

TOP REASONS TO SELECT SuperH

■ SuperH has 2D and 3D graphics capabilities

SuperH RISC and RISC/FPU microprocessors have excellent graphics-handling capabilities, allowing consumer-level products with highly integrated, enhanced features at popular prices. Systems built with other processor architectures require a separate graphics chip, which would increase complexity and add cost.

- **Superscalar architecture (SH-2A, SH-4, and SH-4A)** – Allows FPU operations to occur independently from non-FPU operations of the system. This optimizes the performance of the graphics calculations and minimizes flicker and graphic stalling.
- **Pair single-precision data transfer** – Data transfer can be performed by pair single-precision data transfer instructions, which enable two single-precision (each 32-bit) data items to be transferred for double the transfer performance.
- **Vector/matrix calculation** – Data can be processed efficiently because four multiplication operations and one addition operation are performed in parallel.
- **Geometric-operation instructions** – To enable high-speed computation with a minimum of hardware, geometric-operation instructions perform approximate-value computations.
- **The SH-4 supports two 32-byte store queues (SQ)** to perform high-speed burst writes to external memory. While the contents of one SQ are being transferred to external memory, the other SQ can be written to without a penalty cycle. This functionality is especially useful to transfer video, graphic or display list data to the frame buffer of the graphic processor.

Fast Data Transfers to Frame Buffers Using the SH-4 Store Queues

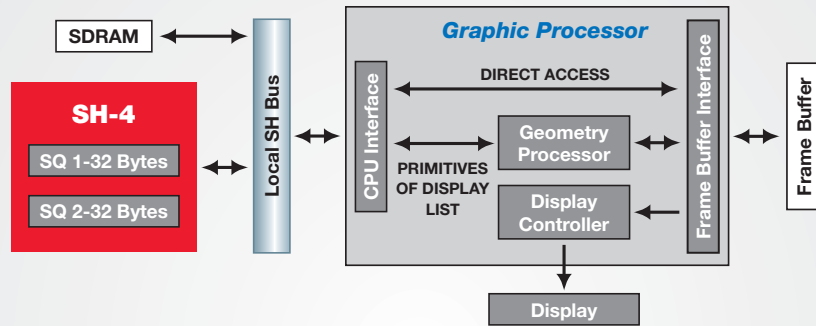

SuperH Flash Roadmap

Memory Structure	2004	2005	2006	2007	2008	2009	2010	2011	2012	2013
NOR 80MHz (0.2- 0.18µm)										
Stack (NOR)		NOR 80MHz (150nm)								
MONOS Metal Oxide Nitride Oxide Silicon	M 50MHz (180nm)	M 80MHz 100MHz (150nm)	M 100MHz (130nm)	M 100MHz (90nm)						
Next-Gen NVMs						New NVM 133MHz (65nm)				
				MRAM				New NVM 166MHz (45nm)		

■ SuperH MCU flash technology leadership

Fourth-generation embedded flash, introduced in 2002, features single-cycle access to on-chip flash memory.

- 0.18µm process, flash size as high as 1MB
- Access as fast as 12.5ns @ 80MHz
- Up to -40°C to +125°C range
- Minimum endurance up to 10,000 erase/write cycles

TOP REASONS TO SELECT SuperH

■ SuperH standard, off-the-shelf solutions

Renesas' qualified middleware and proven reference boards comprise a complete set of solutions that can reduce overall chip count and minimize system cost, without sacrificing performance. These solutions allow a faster time to market.

■ SuperH offers broad OS support

- SuperH offers a broad range of operating system choices to accommodate diverse applications.

■ Sophisticated on-chip debug controller

- Hardware Break Controller provides 2 to 4 independent hardware breakpoints
- Advanced User Debug (AUD) on SH-3 and SH-4 devices provides trace capability
- Third parties offer tools that support the SuperH on-chip debug by utilizing the SuperH hardware resources in the RTOS debug environment
- JTAG BSDL is available for SH-3, SH3-DSP, SH-4, and SH-4A

[JTAG = Joint Test Action Group, a standard developed for boundary scan test.
 BSDL = boundary scan debug layer]

- Emulators are available from Renesas and third-party suppliers
- Development environments are available from Renesas and third-party vendors

■ User Debugging Interface (UDI)

- Supplied with E10A-USB and E200F in-circuit emulators (see page 20)
- The main unit of the emulator is connected through the UDI port to the user's system

SuperH Multimedia Solution Example

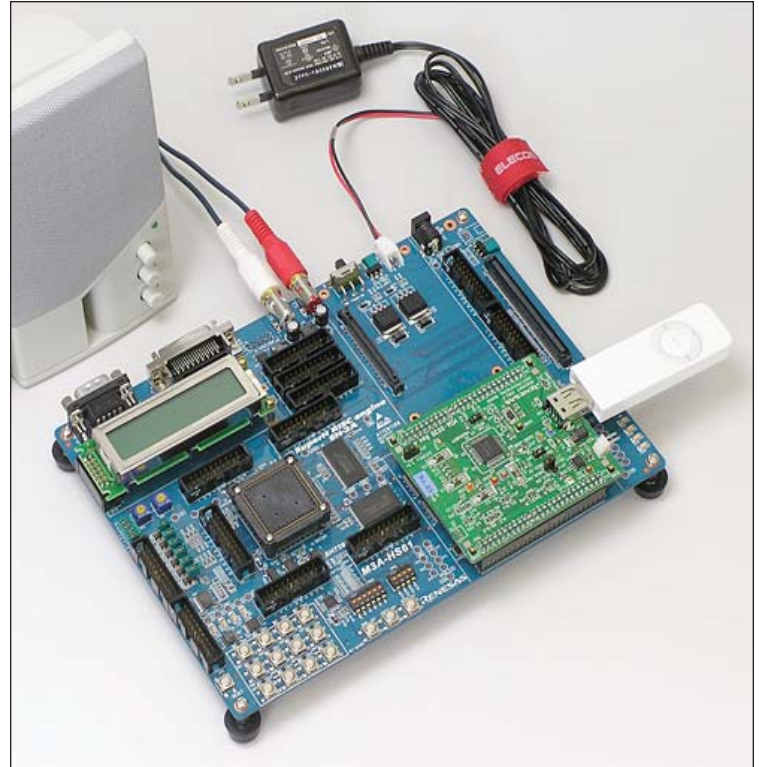

User Debugging Interface (UDI)

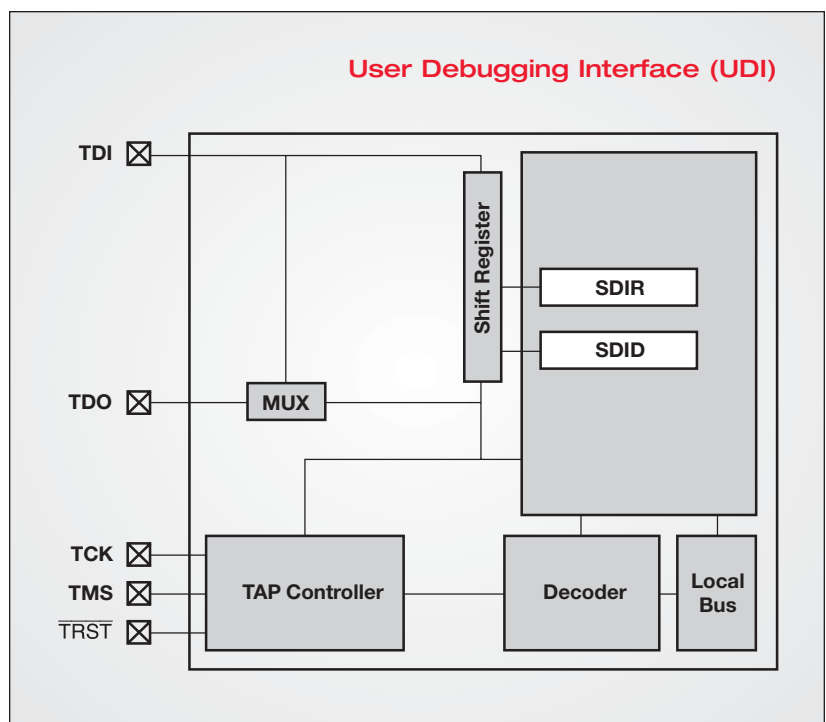

■ LCD Controller

- From 16x1 to 800x600 pixels (SVGA) can be supported
- 11/2/4/6/8/16/18/24 bpp (bit per pixel) with 24-bit color pallet
- 1/2/4 bpp grayscale
- 8-bit frame rate controller
- Supports data formats for STN/dual-STN/TFT panels (8/12/16/18/24-bit bus width)
- Supports variations of the burst length in reading from the synchronous DRAM to achieve high data-read speeds
- Supports inversion of the output signal, if necessary, to match the LCD panel's signal polarity
- Hardware-rotation mode is included to support the use of landscape-format LCD panels as portrait-format LCD panels
- Power control function
- A unified memory architecture is adopted for the LCD controller so the image data for display is stored in system memory

LCD Controller Block Diagram

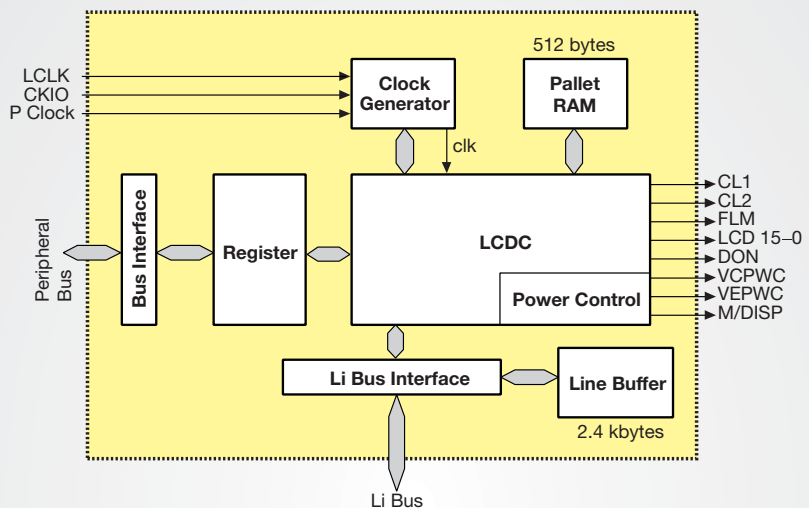

EtherC Function Block Diagram

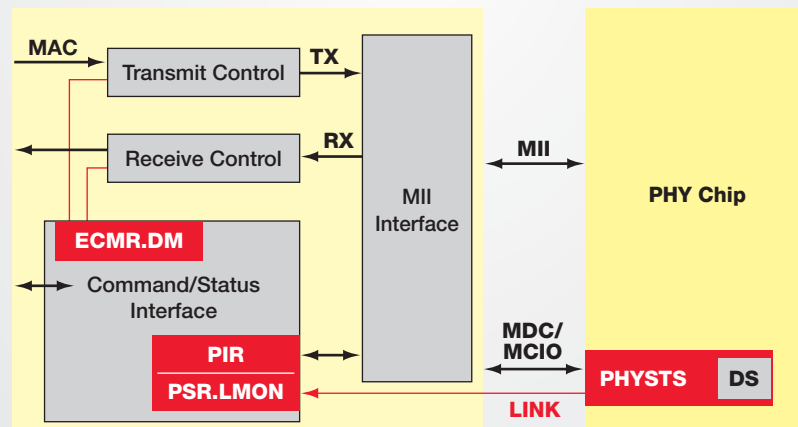

■ Ethernet MAC

- MAC (Media Access Control) functions
 - Data frame assembly/disassembly (IEEE802.3-compliant frame)
 - CSMA/CD link management (collision avoidance, processing in case of collision)
 - CRC/PAD processing
 - Built-in FIFO (2KB for Tx, up to 8KB for Rx)
 - Supports full-duplex and half-duplex transmission/reception
 - Short packets/long packets

- Compatible with MII (Media Independent Interface), RMII (Reduced MII), and GMII (Gigabit MII) standards
 - Converts 8-bit data stream from MAC layer to MII nibble data stream (4 bits)
 - Station management (STA) functions
 - 18 TTL-level signals (5V or 3.3V interface)
 - Variable transfer rate: 10/100/1000Mbps (based on PHY chip features)
- Magic Packet™ (with wake-on-LAN output)
- CAM (Contents Addressable Memory) Interface

■ Controller Area Network (CAN)

- CAN version: Bosch 2.0B active compatible
 - Communication systems: NRZ (Non-Return to Zero) system (with bit-stuffing function)
 - Broadcast communication system
 - Transmission path: Bi-directional 2-wire serial communication
 - Communication speed: Max. 1Mbps (at 40MHz operation)
 - Data length: 0 to 8 bytes
- Number of channels: 1 or 2
- Data buffers: 32 (one receive-only buffer and 31 buffers which can be set for transmission/reception)
- Data transmission: Two methods
 - Mailbox (buffer) number order (high-to-low)
 - Message priority (identifier) reverse-order (high-to-low)
- Supports 12 CPU interrupts
- Supports 7 operating modes
- 16-bit free-running timer (FRT) with flexible clock sources and prescaler
- Other features
 - DTC can be activated by message reception mailbox

■ Universal Serial Bus

- Compatible with Universal Serial Bus standard ver. 2.0
- Four transfer modes (Control, Interrupt, Bulk, Isochronous)
- Root Hub function

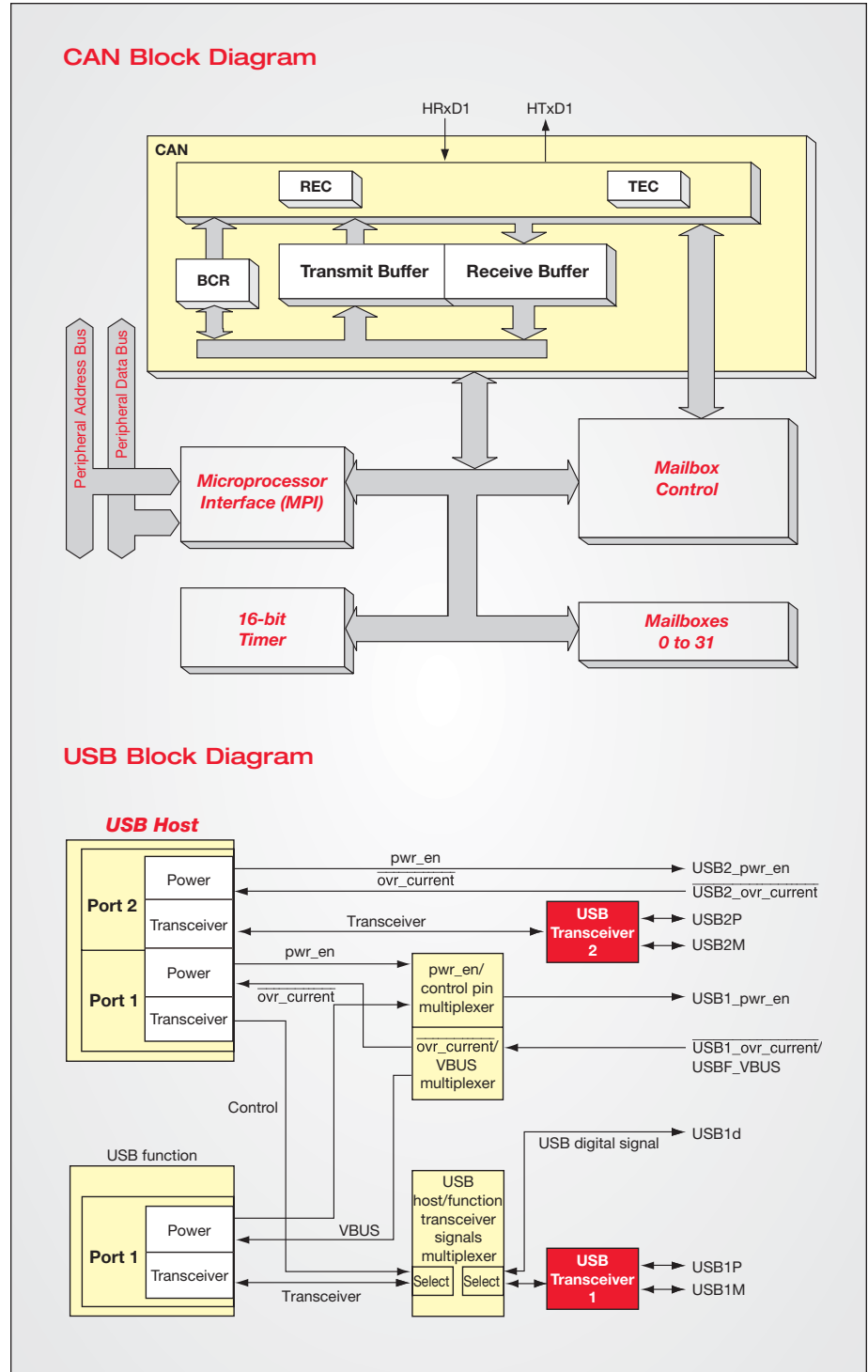

- Offers a range of modes: high-speed mode (480Mbps), full-speed mode (12Mbps) and low-speed mode (1.5Mbps)
- Overcurrent detection feature
- Up to 127 end points control (Host) and 4 end points (Function) can be specified
- On-chip transceiver (multiplex Host or Function)

■ Peripheral Control Interconnect (PCI)

- Compatible with PCI bus operating speeds of 33MHz/66MHz
- Compatible with 32-bit PCI bus
- Up to four PCI master devices running at 33MHz, or one PCI master device at 66MHz, can be connected
- Arbitration control is available as a PCI host function
- Can operate as master or target
- When operating as master, PIO and DMA transfer are available
- Four DMA transfer channels
- Six 32-bit x 16 longword internal FIFO (one for target reading, one for target writing, and four for DMA transfer)
- SRAM, DRAM, SDRAM, DDR-SDRAM, and MPX can be used as external memory for PCI bus data transfers
- 32-bit or 16-bit memory data bus for data transfers with PCI bus (32-bit bus when connected to SDRAM or DDR-SDRAM)
- Support for big-endian and little-endian local bus (PCI bus operates with little endian, while internal bus for peripheral modules operates with big endian)

■ DMA Controller (DMAC)

- Up to twelve channels
- Choice of 8-bit, 16-bit, 32-bit, 64-bit, or 32-byte transfer data length
- Choice of address mode; single or dual; choice of bus mode: cycle steal mode or burst mode
- Two types of DMAC channel priority ranking: fixed-priority mode and round-robin mode

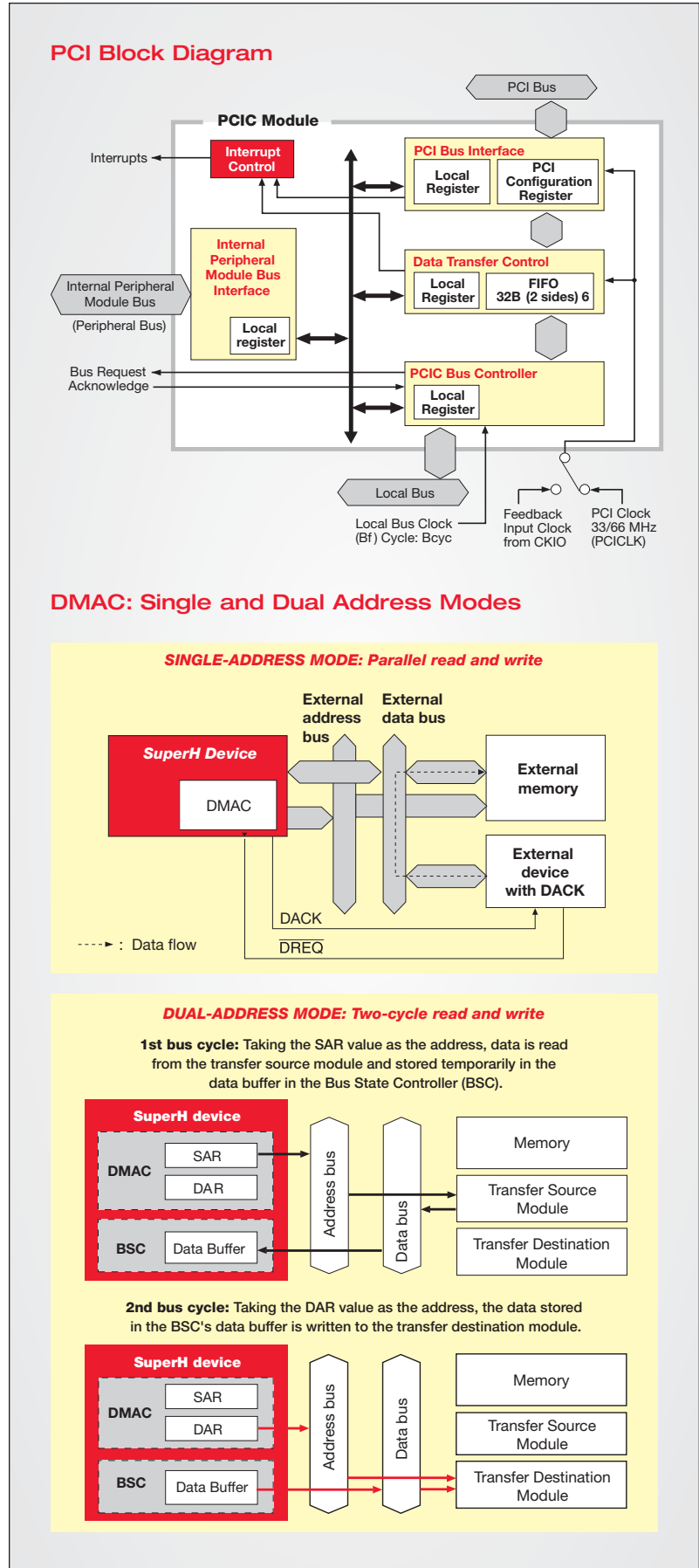

- An interrupt request can be sent to the CPU on completion of the specified number of transfers
- Various DMAC transfer requests are provided:
 - External request
 - On-chip peripheral modules (Transfer requests from the SCI, SCF, and TMU can be accepted on all channels.)
 - Auto-request (A transfer request is generated automatically within the DMAC)
- Channel functions: different transfer modes can be set for each channel

■ Data Transfer Controller (DTC)

- Transfer possible over any number of channels
- 3 transfer modes: normal, repeat, and block transfer
- One activation source can trigger a number of data transfers (chain transfer)
- Direct specification of 32-bit address space
- Activation by software allowed
- Transfer can be set in byte, word, or longword units

■ Host Interface (HIF)

- Connectable to the main CPU with parallel bus
- HIF boot function eliminates the need for boot ROM

■ Motor Management Timer (MMT)

- Triangular-wave comparison-type 6-phase PWM waveform output with non-overlap dead times
- Non-overlap times generated by timer's dead time counters decrease torque pulsations/harmonics for improved voltage utilization
- Toggle output synchronized with PWM period
- PWM output halted by external signal
- PWM duty programmable between 0 and 100%
- Output-off functions
- Adjustable carrier frequency for low switching losses and less audible noise

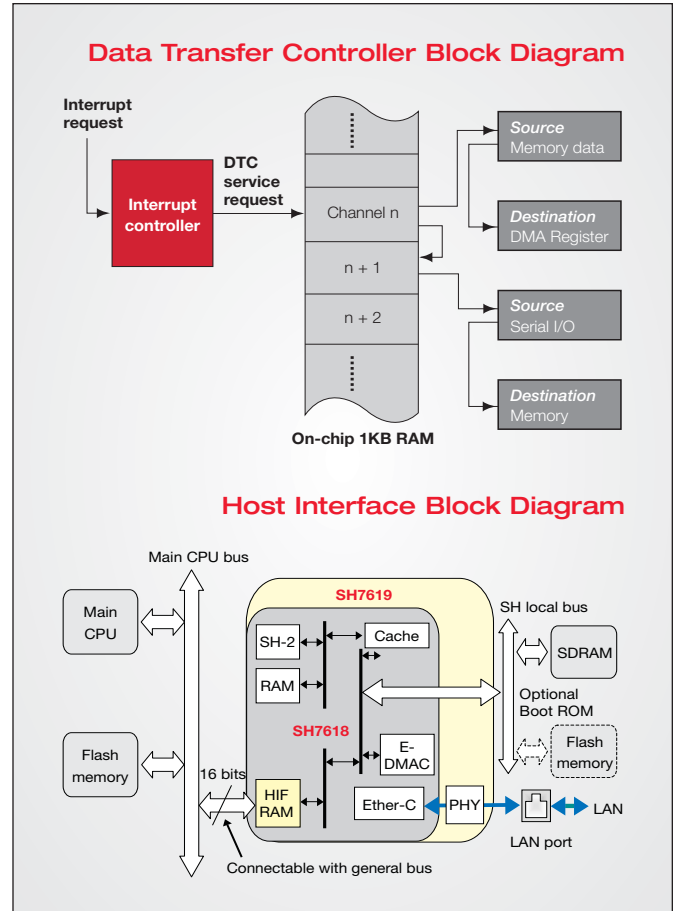

■ Multi-function Timer Unit (MTU)

- Up to 12-phase PWM output with synchronous operation
- 2-phase encoder pulse up/down count
- Counter cascade mode to 32-bit counter
- High sink current (15mA) for 6 pins; can directly drive opto-isolators
- A/D converter trigger signal can be generated
- Dead time can be generated automatically

■ Analog Interfaces

- 4- to 32-channel 10-bit successive-approximation A/D converter
 - Precise current detection for current control
 - Three sample-and-holds with maximum conversion time of 5.4 microseconds
- 2 channel 8-bit D/A converter

■ Overview

Renesas and the many third-party suppliers in the SuperH community provide a wide range of hardware and software tools and other support services. Renesas offers products that cover all stages of the development of embedded systems that use SuperH microcontrollers and microprocessors.

- **Evaluation**—Low-cost or no-cost Renesas tools make it easy to discover the capabilities of SuperH MCUs and test the problem-solving power of the tools themselves, including the High-performance Embedded Workshop (HEW) software development and debugging environment. A free downloadable evaluation version lets you evaluate the ability of the Renesas C/C++ compiler to generate efficient code, and evaluation boards enable you to immediately test that code on known working hardware. In addition, the Renesas Interactive remote engineering laboratory gives you the ability to use your own PC to obtain hands-on experience with powerful software and hardware tools before purchase.

- **Debugging**—When you begin working on the design of your system, you can develop code using the full unlimited compiler in exactly the same HEW environment. To track down bugs, use Renesas’ on-chip and full in-circuit emulators, which have powerful specialized debugging hardware for trapping specific conditions and recording program activity.
- **Final Programming**—Use Renesas’ Flash Development Toolkit, which has an easy-to-use interface, to program your debugged application into any of the many SuperH MCUs that incorporate Renesas’ mature on-chip flash memory technology.

All the tools required for developing SuperH-based applications are available from Renesas distributors. These tools have been developed by groups within the worldwide Renesas organization, experienced engineers who have access to the designers of the devices themselves. Their insight and expertise ensure the best possible tool performance and support.

■ Software

Renesas’ Integrated Development Environment

The High-performance Embedded Workshop (or HEW) is a graphical development environment for C/C++ compiler toolchains with an industry-standard look and feel. Through the use of menus, toolbars, status bars, dockable windows and context-sensitive local menus, HEW integrates key capabilities that can help you create and manage your embedded microcontroller software projects. Its capabilities include:

- Project creation and editing
- Graphical configuration of compiler tools
- Project make
- Debugging
- Version control

HEW provides enhanced functionality and an integrated instruction simulator that allows you to debug application code even when hardware isn’t available. Also, the C/C++ compiler toolchains bundled with HEW generate code that executes faster and/or takes less memory space on Renesas processors.

One familiar interface, many functions

You can quickly learn the powerful tools you need for developing application code, and you have easy-to-use control over those tools.

Moreover, you can work with an interface that remains consistent across the entire range of Renesas MCUs and MPUs for greater efficiency. The interface is also highly

customizable, so you can create an even more efficient environment for developing your application.

Wizards simplify start-up processes

You can start projects fast by taking advantage of HEW’s Project Generator “Wizards.” Let them guide you through the selection of configuration options, debugger targets, and the creation of startup code.

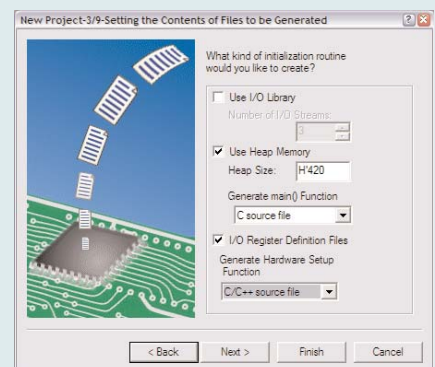

HEW 4 Integrated Development Environment

Project Manager

- Graphical control of compiler/linker options
- Function browser
- Drag-and-drop code templates
- Built-in (or external) project make

Output Window

- Shows messages from build and find-in-files
- Linked to source in editor
- Version-control log

Built-in Editor

- Syntax sensitive coloring
- Multiple files open at once
- Source-level debugging

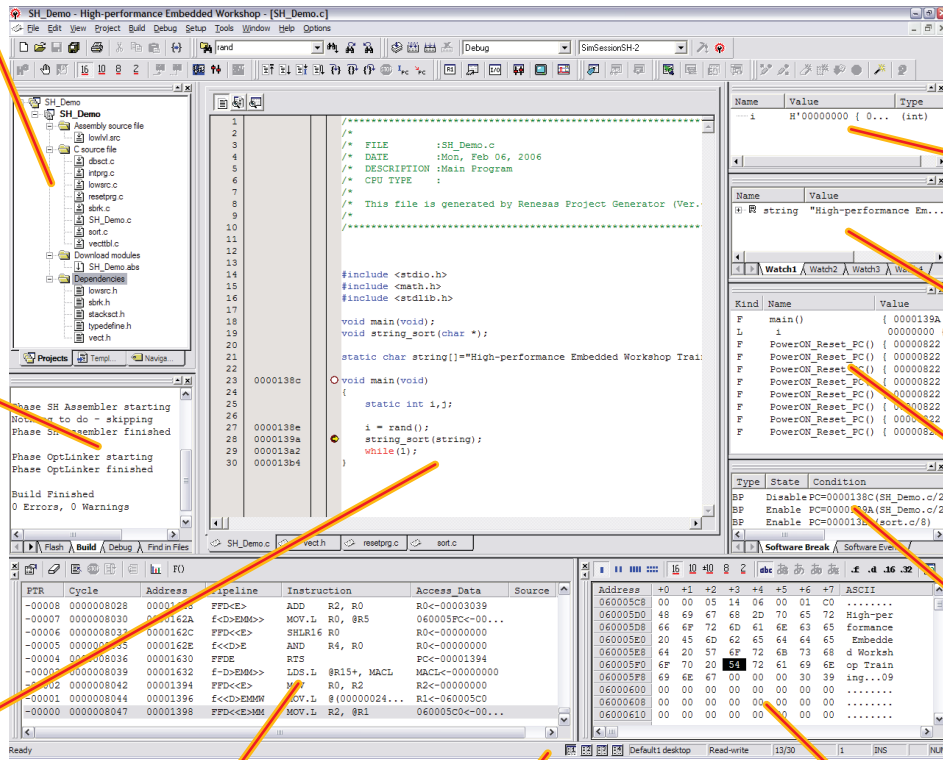

Local Variable Watch

C/C++ Variable Watch

Stack Trace

Complex Break Conditions

Full Bus Trace

Virtual Desktop

- Allows multiple screen layouts to be recalled at the click of a button

Memory View

- Highlights changed values

New features to help optimize your application code

The integrated simulator/debugger has specific features and windows for testing the application code produced in the build process:

- Code profiling window (includes statistical and graphical displays)
- Performance analysis
- Code coverage window

Additional analysis tools help you understand the operation and architecture of your embedded system application:

- Call Walker stack trace analyzer
- Link Map file viewer

HEW Profile Tree and Chart views

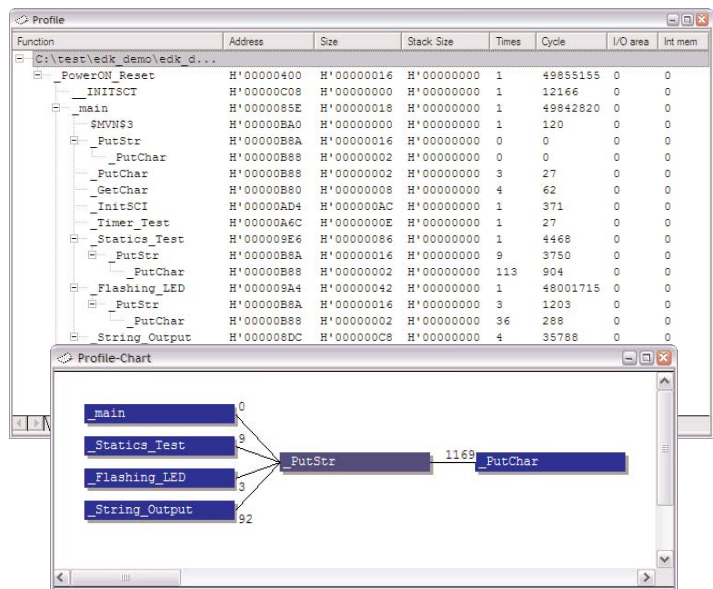

HEW Compiler Toolchain Options Dialogs

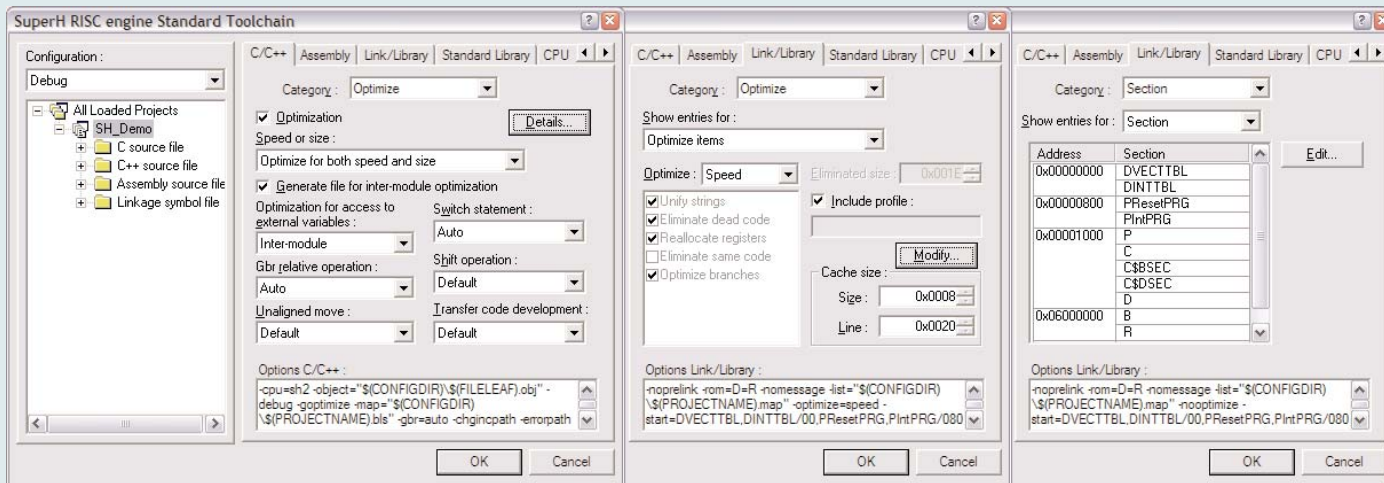

■ Software (continued)

Optimized C/C++ code generation toolchains

The Renesas compiler toolchains (compiler, assembler and linker) support the full C++ language specification and are backward compatible with C. They have extensions for complete embedded system control directly from C, without requiring the use of any assembler code. These extensions cover:

- Interrupt service routines
- Condition control register operations
- Sleep instruction
- Pseudo functions for instructions such as multiply-and-accumulate and decimal add and subtract
- Control of the optimized addressing and function call architecture and instruction set

The inter-module optimizing linker produces optimized software load modules by performing global optimizations on your application.

Free evaluation HEW download

The flexible licensing technology in Renesas' compiler toolchains means you can download a free evaluation copy of HEW with the compiler and generate unlimited code for 60 days. This is very useful for benchmarking optimization efficiency and architecture

performance. After 60 days, code size is limited to 256 Kbytes, which still allows you to evaluate the architecture or experiment with peripherals or, for smaller devices, even complete a full application, since the evaluation version is identical to the full version with the exception of the code size limits.

Flash Development Toolkit

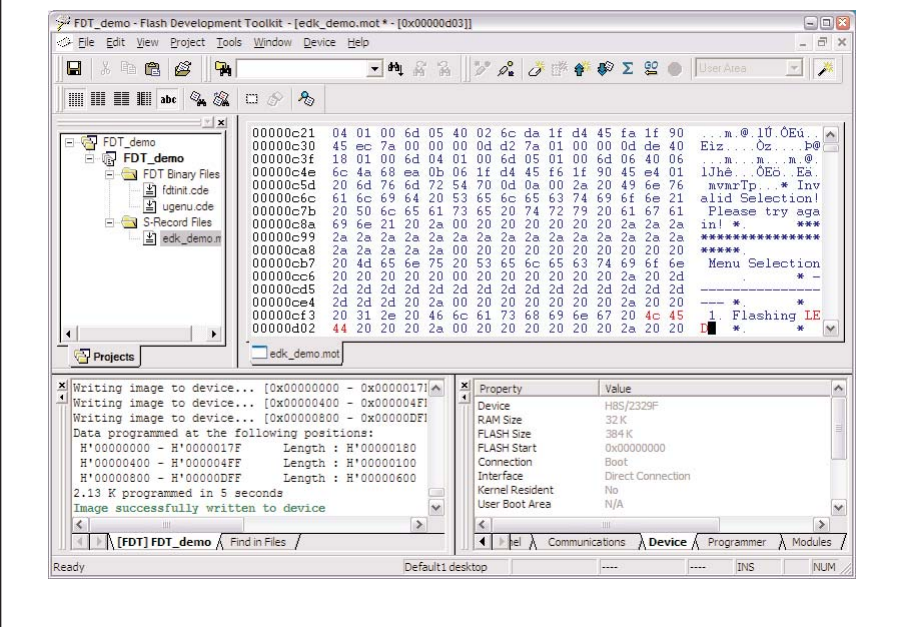

HEW Integrated Debugging

Modular debug target support is provided directly within the HEW environment so you can build your application and debug without leaving HEW. A debug session wizard allows you to easily add a new debug target to your workspace:

- Instruction Simulator
- In-Circuit Emulators (E200F series)
- On-chip Emulators (E10A-USB, E8)
- Evaluation boards using a ROM-resident monitor

Flash Development Toolkit

Renesas' Flash Development Toolkit (FDT) is an easy-to-use utility for programming your code into the on-chip flash memory of SuperH MCUs. You can create workspaces to combine several s-record files into one download image and save connection settings to easily manage device programming.

FDT offers:

- Direct USB connection for USB boot mode devices
- Serial communication at up to 115,200 baud
- Hex image editor
- Extensive messaging that helps hardware development

■ Hardware

Evaluation and Development Kits

Renesas' low-cost Evaluation and Development Kits (EDKs) are inexpensive ways to experience the performance of SuperH microcontrollers and microprocessors. Each kit comes complete with an EDK board and a CD-ROM that contains:

- Evaluation version of HEW with C/C++ compiler and a debug monitor
- Flash Development Toolkit (FDT)
- Quick-Start guide
- Full documentation with sample tutorials and a tutorial Project Generator plug-in for HEW

Renesas Starter Kits

RSKs are the latest line of evaluation and development kits from Renesas. The target boards provide a standardized platform for all Renesas MCUs (H8, R8C, M16C, M23C and SuperH). The kit comprises all of the content of the EDK kits and – additionally – a USB on-chip debugger that provides full remote boot programming and debugging.

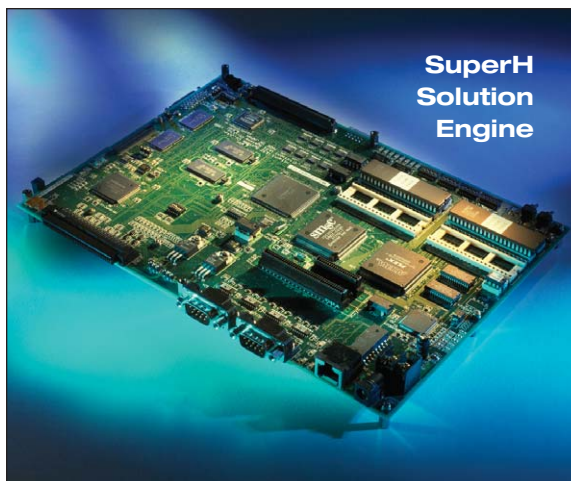

SuperH Solution Engine

The SuperH architecture provides advantages in price, performance, power and code density. The Solution Engine family of development boards make implementing SuperH-based designs easy and provide complete system platforms ready for application development with spacious SDRAM and FLASH memory to enable development of large and complex programs.

They also enable rapid evaluation of the SuperH architecture and available peripherals.

Multiple vendors support the Solution Engine platforms with real-time operating systems (RTOSs), board support packages and middleware to enable rapid product implementation for designs that require operating systems. The Solution Engine boards support

■ Hardware (continued)

multiple SuperH devices. Typical features of the Solution Engine include:

- External flash for user code
- EPROM containing monitor code
- JTAG connector easily connects to E10A on-chip emulator
- Unbuffered CPU bus connectors provide direct connection to address data and control lines
- Expansion slot for daughter boards (buffered CPU bus provides direct connection to address data and control lines)
- I/O connectors (for SuperH peripheral signals)

E10A-USB on-chip emulators

The E10A-USB emulators, designed to connect with Renesas' JTAG on-chip debugging interfaces, provide real-time debugging on the target device, using the dedicated debugging resources built into the target microcontroller in your user hardware. The on-chip emulators connect to the target system via an

interface that can be used both to debug the system and to program the MCU's on-chip flash memory.

E10A-USB emulators use plug-and-play USB 2.0 compatible interfaces for easy connection to both notebook computers and desktop machines. These emulators offer:

- 255 PC breakpoints
- One hardware breakpoint on data and address
- The ability to save a record of up to the last eight branches
- On-chip flash programming

The E10A-USB emulator is available in two configurations:

- HS0005KCU01H (14pin H-UDI)
- HS0005KCU02H (14pin H-UDI + 36pin AUD)

Both provide on-chip debugging via the Renesas H-UDI (JTAG) interface.

Advanced User Debug (AUD)

Renesas' Advanced User Debug interface allows you to trace real-time data out of the device while it is running in-system.

You can configure the AUD trace to stream source and destination branch addresses, memory accesses (from user-specified data buses and "windows" in the address space) and also source-level variables via a special software-trace function call.

This data is compressed on-chip, streamed out of the AUD port, and then captured in a dedicated trace buffer in the E10A-USB (HS0005KCU02H model only) or E200F (see next section).

E200F Configurable On-Chip/In-Circuit Emulator

The E200F is an expandable emulation system for both on-chip and in-circuit debugging. It provides all of the same H-UDI (JTAG) and AUD debug features as the E10A-USB, but with enhanced capabilities and system expansion with add-on options.

Enhanced Capabilities

The E200F has a high-speed USB 2.0 host interface for fast debug file download and data upload. Eight AUD Event points allow you to halt on a match of AUD trace data such as branch source/destination address, windowed memory access and software data variable trace. Four external probe inputs and one external trigger output are also included.

Performance Analysis

The E200F emulator provides three methods of application performance analysis:

- On-chip performance
- AUD performance analysis
- Real-time profiling

The real-time profiling method gives execution statistics for



AUD on-chip control logic

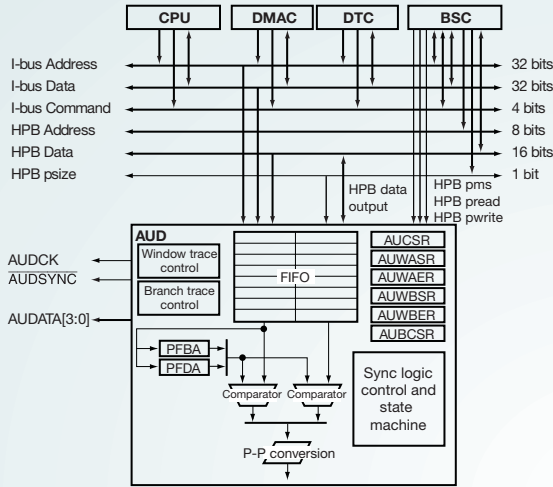

- Legend**
- AUCSR : AUD control register
 - AUWASR : AUD window A start address register
 - AUWAER : AUD window A end address register
 - AUWBSR : AUD window B start address register
 - AUWBESR : AUD window B end address register
 - AUWBCSR : AUD bus master control register
 - PFBA : Previous full branch address
 - PFDA : Previous full data address

Advanced User Debug (AUD) Trace

AUD Configuration dialog in HEW

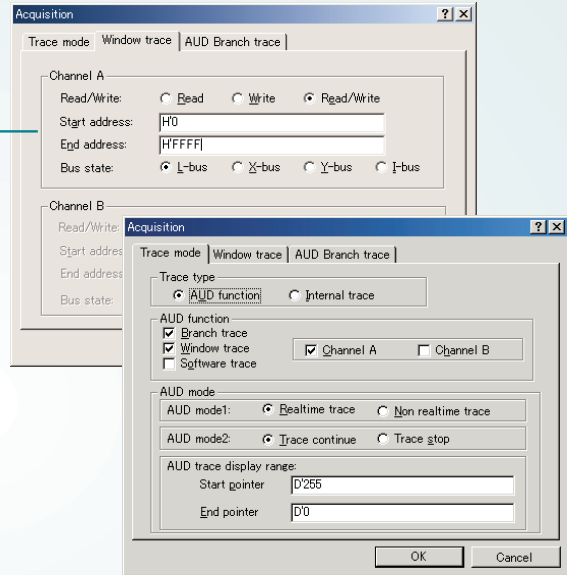

AUD Trace View in HEW showing memory window trace

PTR	IP	Type	Bus	R/W	Address	Data	Source	Label
-000337	-D'000255	BRANCH			0000104C			
-000336		DESTINATION			00001054			
-000335	-D'000254	MEMORY	L-Bus	WRITE	0000FFE4	00006679		
-000334	-D'000253	MEMORY	L-Bus	WRITE	0000FFD0	00006679		
-000333	-D'000252	BRANCH			00001062			
-000332		DESTINATION			00001044		j = rand();	
-000331	-D'000251	MEMORY	L-Bus	WRITE	0000FFE0	00000008		
-000330	-D'000250	BRANCH			00001044		j = rand();	
-000329		DESTINATION			000011F0			_rand
-000328	-D'000249	MEMORY	L-Bus	WRITE	0000FFB0	00000000		
-000327	-D'000248	MEMORY	L-Bus	READ	00001214	0000540C		
-000326	-D'000247	MEMORY	L-Bus	READ	00001218	41C64E6D		

functions in up to 4MB of the system address space (8 x 512K blocks). An optional profiling expansion board increases the profiling capability to 12MB (24 x 512K blocks).

External Bus Trace

You can further expand the E200F system by connecting the optional Bus Trace unit. This lets you synchronously trace 256K external bus cycles from the device in your target system and examine them in the HEW IDE.

The Bus Trace unit also provides 10 Bus Event points that you can use to control trace acquisition or halt program execution.

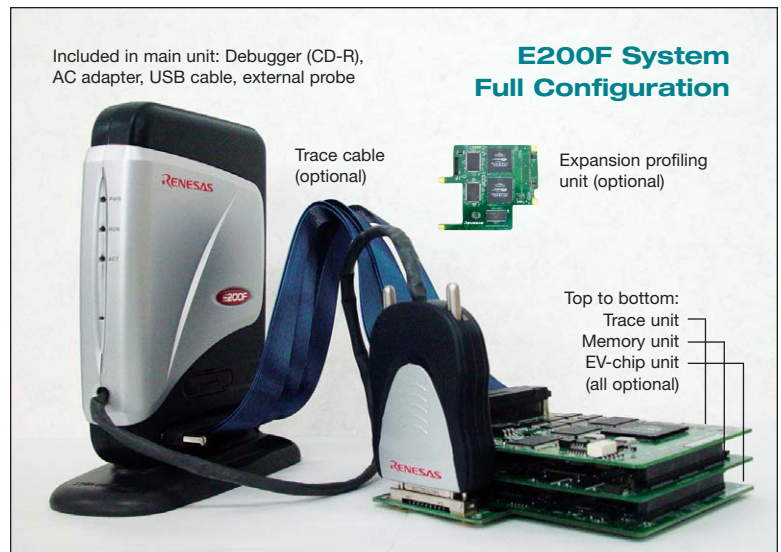

■ Hardware (continued)

Evaluation Chip Unit

The special “bond-out” chip on the optional Evaluation Chip unit brings out internal CPU buses, which – when used with the Bus Trace unit – give you full bus trace from within the device itself. The Evaluation Chip unit has connectors on the underside that can connect, via a user interface adaptor, to your target system in place of the regular chip. You can then emulate the device in your target system with access to all the E200F Emulator’s enhanced debugging features – even with devices that lack the AUD trace output.

Emulation Memory Units

The optional Emulation Memory units give you 8 or 16 Mbytes of system memory. When used with the Evaluation Chip unit, you can do real-time software debugging without any target hardware.

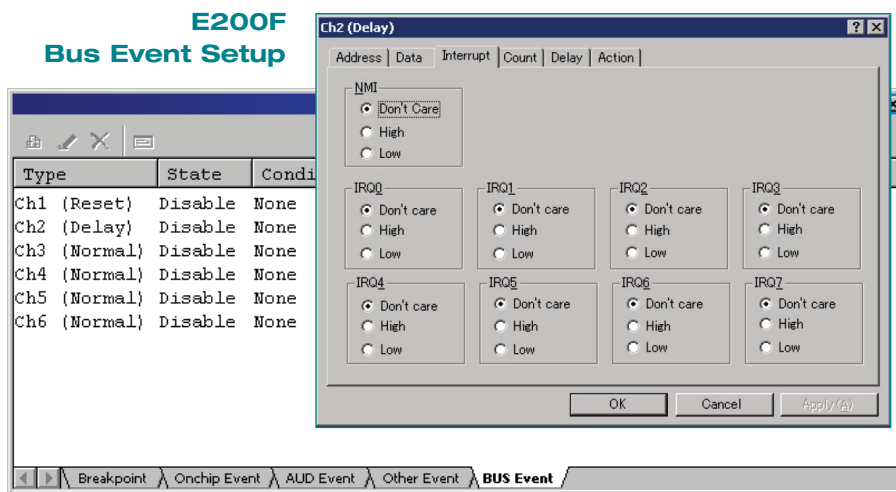

Real-time profiling

Page	Function	Address	Size	Count	Time
1	_PowerON_Reset_PC	H' 800	H' 30	47789	18253h054min011s721ms117us956ns
1	_Manual_Reset_PC	H' 830	H' 1C	61453	18253h054min011s721ms117us956ns
1	_INT_Illegal_code	H' 84C	H' 4	47789	18253h054min011s721ms117us956ns
1	_Dummy	H' 850	H' 4	61453	18253h054min011s721ms117us956ns
1	_sbrk	H' 1000	H' 24	47789	18253h054min011s721ms117us956ns
1	_main	H' 1024	H' A6	61453	18253h054min011s721ms117us956ns
1	_f1	H' 10D8	H' C	47789	18253h054min011s721ms117us956ns
1	_h2	H' 10EC	H' 8	61453	18253h054min011s721ms117us956ns
1	_func3	H' 10F4	H' 16	47789	18253h054min011s721ms117us956ns
1	_func4	H' 110A	H' 4	61453	18253h054min011s721ms117us956ns

SuperH Tool Selector

Series	Group	Suggested Starter Kit or Reference Platform	E10A-USB On-chip Debug Emulator	Base Unit	E200F Full Emulator ²		IDE ³ (C Compiler)
					Evaluation chip board	User interface board	
SH-Tiny	7125	R0K571242S000BR	HS0005KCU01H	R0E0200F1EMU00	R0E570800VKK00	R0E571250CFK00	RTA-HEWSH-1U
SH-2	7146	EDK7145	HS0005KCU01H	R0E0200F1EMU00	R0E570800VKK00	R0E571460CFJ00	RTA-HEWSH-1U
SH-2	7086	R0K570865S000BE	HS0005KCU02H ¹	R0E0200F1EMU00	R0E570800VKK00	R0E570860CFK00	RTA-HEWSH-1U
SH-2A	7211	R0K572115S000BE	HS0005KCU02H ¹	R0E0200F1EMU00	R0E572110VKK00	R0E572110CFK00	RTA-HEWSH-1U
SH-2A	7201	R0K572011S000BE	HS0005KCU02H ¹	-	-	-	RTA-HEWSH-1U
SH-2A	7203	R0K572030S000BE	HS0005KCU02H ¹	R0E0200F1EMU00	-	-	RTA-HEWSH-1U
SH-2A	7206	MS7206SE01	HS0005KCU02H ¹	R0E0200F1EMU00	R0E572060VKK00	R0E572060CFK00	RTA-HEWSH-1U
SH-2	7618	MS7618ACP01	HS0005KCU01H	-	-	-	RTA-HEWSH-1U
SH-2	7619	MS7619SE01	HS0005KCU01H	-	-	-	RTA-HEWSH-1U
SH3-DSP	7712	MS7712SE01	HS0005KCU02H ¹	-	-	-	RTA-HEWSH-1U
SH3-DSP	7720	MS7720RP02	HS0005KCU02H ¹	-	-	-	RTA-HEWSH-1U
SH-4	7760	MS7760CP02P	HS0005KCU02H ¹	R0E0200F0EMU00	-	-	RTA-HEWSH-1U
SH-4A	7780	MS7780SE03	HS0005KCU02H ¹	R0E0200F0EMU00	-	-	RTA-HEWSH-1U
SH-4A	7763	MS7763SE02Y	HS0005KCU02H ¹	-	-	-	RTA-HEWSH-1U

NOTES:

1. Includes AUD real-time trace support and both 36-pin AUD & 14-pin H-UDI target cables.
2. E200 emulation system, can operate with the base unit alone (see website for details).
3. Five-user pack and floating network licences also available (see website for details).

■ Third-party Development Tools

Many third-party experts offer development tools supported by design services, RTOS, compilers, board-level solutions, custom firmware, and board-support packages (BSPs) to meet the needs of customers developing SuperH-based products. Product-ready single-board computers (SBCs) and application-specific reference designs offered by systems integrators are fully developed solutions designed for the lowest cost

and highest performance. By embedding these engineered solutions in systems, customers can greatly reduce overall system design/debug time and development schedule risk because the board design, integration and debug, driver development, driver optimization, and driver and board testing have already been done. As a result, customers can bring end products to market months faster.



Third-party RTOS Support

	SH-1 / SH-2	SH-2A	SH-3	SH-4	SH-4A	SH-Mobile
ATI Nucleus	✓	soon	✓	✓	✓	✓
CMX	✓		✓	✓	✓	
Express Logic ThreadX	✓	soon	✓	✓		
LynxOS				✓		
Microsoft Windows®CE			✓	✓	✓	
Montavista Linux			✓	✓		
Open Source Linux	soon		✓	✓	✓	✓
uClinux		soon				
OS9			✓	✓		
QNX				✓	soon	
WindRiver VxWorks	✓		✓	✓	soon	

Third-party Compiler Support

	SH-1 / SH-2	SH-2A	SH-3	SH-4	SH-4A	SH-Mobile
Altium	✓		✓	✓		
GAIO	✓	✓	✓	✓		
GHS	✓	✓	✓	✓	✓	
GNU	✓	✓	✓	✓	✓	✓
IAR	✓		✓	✓		
Metrowerks	✓		✓	✓		

Third-party System Integrators

	Hardware	WindowsCE	Linux	Other	Website
BSquare		✓			www.bsquare.com
CalAmp	✓	✓	✓	✓	www.calamp.com
California Software Labs	✓	✓	✓		www.cswl.com
JJPlus	✓		✓		linux.jjplus.com
Logic Products Development	✓	✓			www.logicpd.com
Software Research Associates			✓		www.sraoss.com
Systemic Realtime Design	✓		✓	✓	www.sysrtime.com
TrygTech		✓			www.trygtech.com
Kenati Technologies			✓	✓	www.kenati.com
Trinity Convergence			✓		www.trinityconvergence.com
TrollTech			✓	✓	www.trolltech.com

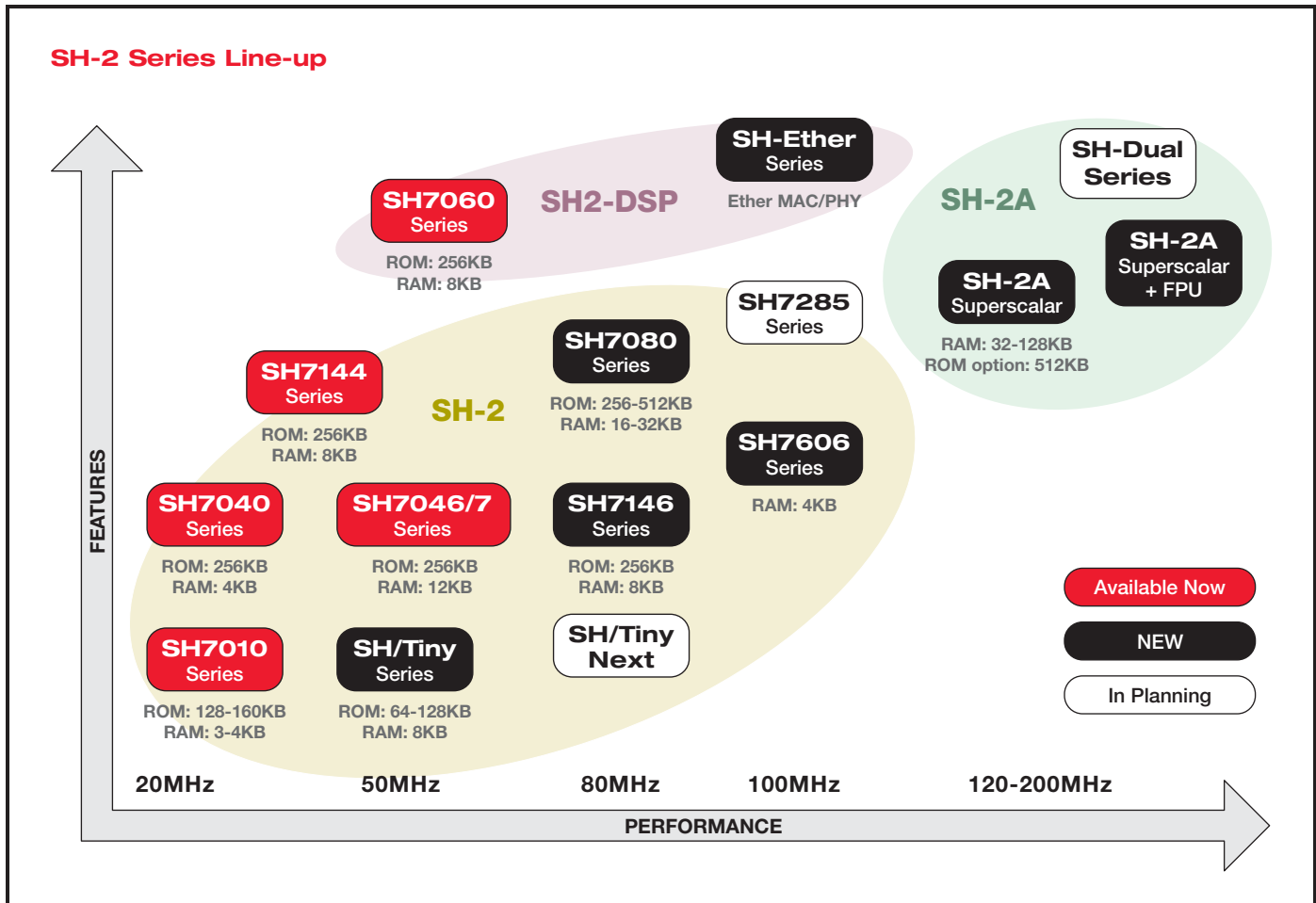

■ Features

- Large size and high-performance on-chip memory: Up to 512KB on-chip flash memory and up to 32KB on-chip RAM
- Direct connection to external memory (e.g., SDRAM, SRAM and Flash) via 8/16/32-bit external data bus
- Devices with on-chip DSP enable accurate current/position control. The RISC/DSP devices allow concurrent monitoring and controlling of a system
- Special advanced Motor Management Timer with outputs for 6-phase PWM waveform (complementary/reset-synchronized) with programmable dead-time for 3-phase motor control
- Special Multi-function Timer Unit 3-phase motor controller includes 2 quadrature encoding channels for speed/position detection of rotor
- MTU and MMT have error input for emergency PWM shutdown
- Synchronized A/D converter enables precise current detection for motor control
- Industry-standard CAN interface for networking communication in applications such as factory automation
- Excellent MIPS/watt and low-power support, as well as low-voltage options
- On-chip debug hardware allows low-cost software debugging; no in-circuit emulator required
- Other on-chip peripherals include DMAC, DTC, SCI, up to 149 I/O ports, etc.

■ Applications

Industrial: AC/DC drives, inverters, servos/motion controllers, robotics, machine tools, factory automation

Consumer/Office Appliances: Air conditioners, washers, refrigerators, DVD recorders, digital cameras, LCD projectors, multi-function printers, seismic monitoring systems, etc.

Automotive: Power door closers, seat positioners, starter/generators, air conditioners, electric power steering, etc.

Medical: Heart-rate monitors, dental equipment, etc.

SH-2 Series Selector Guide

Series	Group	Device Number	Flash (Kbytes)	RAM (Kbytes)	Vcc min	Vcc max	max MHz @ Vcc max	Power-Down Modes	8-bit timers	16-bit timers	Watchdog Timers	Motor Control PWM Timer	A/D 10-bit resolution	D/A 8-bit resolution	Serial (sync/async)	DTC	DMA Channels	External Interrupts	GPIO	Special Features	Package Code
SH-2	7046	HD64F7046F50V	256	12	4.0	5.5	50	3	-	5	1	1	12	-	2	Y	-	5	54	MTU, CMT, MMT	FP-80Q
	7047	HD64F7047F50V	256	12	4.5	5.5	50	4	-	5	1	1	16	-	3	Y	-	5	69	MTU, MMT, CAN	P-100M
	7144	HD6417144F50V	-	8	3.0	3.6	50	3	-	5	1	1	8	-	4	Y	4	9	82	MTU, I ² C, AUD	FP-112B
	7144	HD6417144FW50V	-	8	3.0	3.6	50	3	-	5	1	1	8	-	4	Y	4	9	82	MTU, I ² C, AUD	FP-112B
	7144	HD64F7144F50V	256	8	3.0	3.6	50	3	-	5	1	1	8	-	4	Y	4	9	82	MTU, I ² C, AUD	FP-112B
	7144	HD64F7144FW50V	256	8	3.0	3.6	50	3	-	5	1	1	8	-	4	Y	4	9	82	MTU, I ² C, AUD	FP-112B
	7145	HD6417145F50V	-	8	3.0	3.6	50	3	-	5	1	1	8	-	4	Y	4	9	106	MTU, I ² C, AUD	FP-144F
	7145	HD6417145FW50V	-	8	3.0	3.6	50	3	-	5	1	1	8	-	4	Y	4	9	106	MTU, I ² C, AUD	FP-144F
	7145	HD64F7145F50V	256	8	3.0	3.6	50	3	-	5	1	1	8	-	4	Y	4	9	106	MTU, I ² C, AUD	FP-144F
	7145	HD64F7145FW50V	256	8	3.0	3.6	50	3	-	5	1	1	8	-	4	Y	4	9	106	MTU, I ² C, AUD	FP-144F
	7146	R5F71464AN80FPV	256	8	4.0	5.5	80	4	-	11	1	-	12	-	3	Y	-	5	57	MTU2, MTU2S, CMT	FP-80W
	7146	R5F71464AD80FPV	256	8	4.0	5.5	80	4	-	11	1	-	12	-	3	Y	-	5	57	MTU2, MTU2S, CMT	FP-80W
	7146	R5F71494AN80FPV	256	8	4.0	5.5	80	4	-	11	1	-	12	-	3	Y	-	5	75	MTU2, MTU2S, CMT	FP-100U
	7146	R5F71494AD80FPV	256	8	4.0	5.5	80	4	-	11	1	-	12	-	3	Y	-	5	75	MTU2, MTU2S, CMT	FP-100U
	7080	R5F70834AN80FTV	256	16	3.0	5.5	80	4	-	11	1	-	8	-	4	Y	4	9	73	MTU2, MTU2S, CMT	TFP-100B
	7080	R5F70834AD80FTV	256	16	3.0	5.5	80	4	-	11	1	-	8	-	4	Y	4	9	73	MTU2, MTU2S, CMT	TFP-100B
	7080	R5F70844AN80FPV	256	16	3.0	5.5	80	4	-	11	1	-	8	-	4	Y	4	9	84	MTU2, MTU2S, I ² C	FP-112E
	7080	R5F70844AD80FPV	256	16	3.0	5.5	80	4	-	11	1	-	8	-	4	Y	4	9	84	MTU2, MTU2S, I ² C	FP-112E
	7080	R5F70854AN80FPV	256	16	3.0	5.5	80	4	-	11	1	-	8	-	4	Y	4	9	108	MTU2, MTU2S, I ² C	FP-144L
	7080	R5F70854AD80FPV	256	16	3.0	5.5	80	4	-	11	1	-	8	-	4	Y	4	9	108	MTU2, MTU2S, I ² C	FP-144L
	7080	R5F70855AN80FPV	512	32	3.0	5.5	80	4	-	11	1	-	8	-	4	Y	4	9	108	MTU2, MTU2S, I ² C	FP-144L
	7080	R5F70855AD80FPV	512	32	3.0	5.5	80	4	-	11	1	-	8	-	4	Y	4	9	108	MTU2, MTU2S, I ² C	FP-144L
	7080	R5F70865AN80FPV	512	32	3.0	5.5	80	4	-	11	1	-	16	-	4	Y	4	9	134	MTU2, MTU2S, I ² C	FP-176E
	7080	R5F70865AD80FPV	512	32	3.0	5.5	80	4	-	11	1	-	16	-	4	Y	4	9	134	MTU2, MTU2S, I ² C	FP-176E
	7606	HD6417606BG100V	-	4	3.0	3.6	100	3	-	-	1	-	-	-	3	-	-	9	78	HIF, CMT, SDRAM, PCMCIA	BP-176V
	7606	HD6417606BGN100V	-	4	3.0	3.6	100	3	-	-	1	-	-	-	3	-	-	9	78	HIF, CMT, SDRAM, PCMCIA	BP-176V
	7606	HD6417606BGW100V	-	4	3.0	3.6	100	3	-	-	1	-	-	-	3	-	-	9	78	HIF, CMT, SDRAM, PCMCIA	BP-176V
SH-Tiny	7125	R5F71242D50FPV	64	8	4.5	5.5	50	4	-	8	1	-	8	-	3	-	-	4	31	MTU2, CMT	FP-48F
	7125	R5F71242N50FPV	64	8	4.5	5.5	50	4	-	8	1	-	8	-	3	-	-	4	31	MTU2, CMT	FP-48F
	7125	R5F71243D50FPV	128	8	4.5	5.5	50	4	-	8	1	-	8	-	3	-	-	4	31	MTU2, CMT	FP-48F
	7125	R5F71243N50FPV	128	8	4.5	5.5	50	4	-	8	1	-	8	-	3	-	-	4	31	MTU2, CMT	FP-48F
	7125	R5F71252D50FAV	64	8	4.5	5.5	50	4	-	8	1	-	8	-	3	-	-	5	45	MTU2, CMT	FP-64A
	7125	R5F71252N50FAV	64	8	4.5	5.5	50	4	-	8	1	-	8	-	3	-	-	5	45	MTU2, CMT	FP-64A
	7125	R5F71252D50FPV	64	8	4.5	5.5	50	4	-	8	1	-	8	-	3	-	-	5	45	MTU2, CMT	FP-64K
	7125	R5F71252N50FPV	64	8	4.5	5.5	50	4	-	8	1	-	8	-	3	-	-	5	45	MTU2, CMT	FP-64K
	7125	R5F71253D50FAV	128	8	4.5	5.5	50	4	-	8	1	-	8	-	3	-	-	5	45	MTU2, CMT	FP-64A
	7125	R5F71253N50FAV	128	8	4.5	5.5	50	4	-	8	1	-	8	-	3	-	-	5	45	MTU2, CMT	FP-64A
	7125	R5F71253D50FPV	128	8	4.5	5.5	50	4	-	8	1	-	8	-	3	-	-	5	45	MTU2, CMT	FP-64K
	7125	R5F71253N50FPV	128	8	4.5	5.5	50	4	-	8	1	-	8	-	3	-	-	5	45	MTU2, CMT	FP-64K
	SH2-DSP	7065	HD64F7065SV	256	8	3.0	3.6	60	4	-	6	1	-	8	2	3	-	4	9	118	MMT, DSP, CMT, TPU
SH-2A	7206	R5S72060W200FPV	-	128	1.15	1.35	200	3	-	9	1	1	8	2	4	-	8	17	79	MTU2, MTU2S, CMT, SDRAM	FP-176CV
	7211	R5F72115D160FPV	512	32	3.0	3.6	160	3	-	2	1	9	8	2	4	-	8	9	75	MTU2, MTU2S, CMT, I ² C	FP-144L
	7203	R5S72030W200FP	-	32	1.15	1.35	80	3	2	6	1	-	8	2	8	-	8	17	82	FPU, LDCDC, USB, I ² C, SSI, MTU2, CAN, FLCTL, SDRAM	FP-240V
	7261	R5S72611C120FPV	-	32	1.15	1.35	120	3	2	6	1	-	8	2	8	-	8	17	123	MTU2, CAN, I ² C, FPU, SSI, SDRAM	FP-176EV
	7261	R5S72611P80FPV	-	32	1.15	1.35	80	3	2	6	1	-	8	2	8	-	8	17	123	MTU2, CAN, I ² C, FPU, SSI, SDRAM	FP-176EV
7261	R5S72611C120FPV	-	32	1.15	1.35	120	3	2	6	1	-	8	2	8	-	8	17	123	MTU2, CAN, I ² C, FPU, SSI, SDRAM	FP-176EV	

SH-Ether Series Line-up



FEATURES

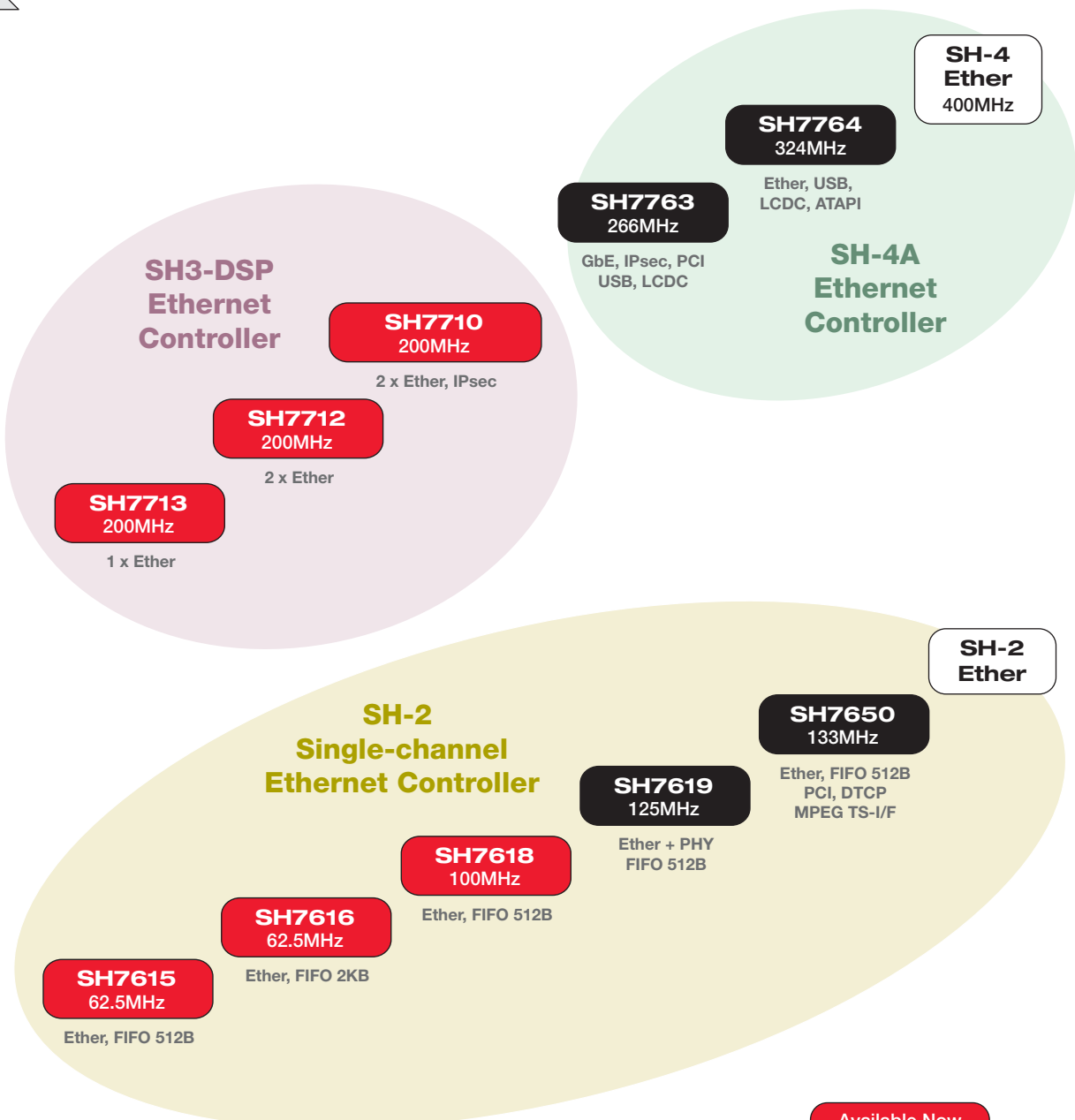

SH7713
200MHz
1 x Ether

SH7712
200MHz
2 x Ether

SH7710
200MHz
2 x Ether, IPsec

**SH3-DSP
Ethernet
Controller**

SH7763
266MHz
GbE, IPsec, PCI
USB, LCDC

SH7764
324MHz
Ether, USB,
LCDC, ATAPI

**SH-4
Ether**
400MHz

**SH-4A
Ethernet
Controller**

SH7615
62.5MHz
Ether, FIFO 512B

SH7616
62.5MHz
Ether, FIFO 2KB

SH7618
100MHz
Ether, FIFO 512B

SH7619
125MHz
Ether + PHY
FIFO 512B

SH7650
133MHz
Ether, FIFO 512B
PCI, DTCP
MPEG TS-I/F

**SH-2
Single-channel
Ethernet Controller**

**SH-2
Ether**

Available Now

NEW

In Planning

PERFORMANCE



■ Features

- Built-in 10/100Mbps or 10/100/1000Mbps Ethernet MAC with up to 8KB FIFO for better network efficiency and dedicated DMAC for efficient data transfer
- Easy connectivity via built-in peripherals such as USB function controllers
- Large-size on-chip memory: Up to 16KB RAM and 32/32KB instruction/data cache for higher performance
- Widely supported by third parties and Renesas; product-ready platforms, schematics, software and middleware available
- On-chip hardware support for debugging
- Clever power management
 - Three power-down modes for lower power consumption
 - Clock gearing enables clock to be changed on the fly
 - On-chip hardware support for debugging
- Highly-integrated RISC CPUs in compact micro-BGA and QFP packages reduce board space and system cost

■ Applications

Network/Communication:

Network printers, network security cameras, networked factory automation terminals, routers, cable modems, home gateways, etc.

Office Appliances:

Printers, scanners, postage meters

Consumer:

DVD recorders, HDD recorders, digital home appliances

SH-Ether Series Selector Guide

Series	Group	Device Number	RAM (Kbytes)	Vcc min	Vcc max	max MHz @ Vcc max	Watchdog Timer	A/D 10-bit resolution	D/A 8-bit resolution	Serial (Sync/Async)	SSU (SPI Compatible)	DMA Channels	External Interrupts	GPIO	Special Features	Package Code
SH2-DSP	7616	HD6417616ARFV	8	3.0	3.6	62.5	1	-	-	5	-	2	5	30	DSP, Ether MAC, SDRAM	FP-208C
SH-2	7618	HD6417618RBGN100V	4	3.0	3.6	100	1	-	-	3	-	-	9	78	HIF, Ether MAC, PCMCIA, SDRAM	BP-176V
	7618	HD6417618RBGN100V	4	3.0	3.6	100	1	-	-	3	-	-	9	78	HIF, Ether MAC, PCMCIA, SDRAM	BP-176V
	7618	HD6417618RBGW100V	4	3.0	3.6	100	1	-	-	3	-	-	9	78	HIF, Ether MAC, PCMCIA, SDRAM	BP-176V
	7619	R4S76190B125BGV	16	3.0	3.6	125	1	-	-	4	-	4	9	78	HIF, Ether MAC PHY, PCMCIA, SDRAM	BP-176V
	7619	R4S76190N125BGV	16	3.0	3.6	125	1	-	-	4	-	4	9	78	HIF, Ether MAC PHY, PCMCIA, SDRAM	BP-176V
	7619	R4S76190W125BGV	16	3.0	3.6	125	1	-	-	4	-	4	9	78	HIF, Ether MAC PHY, PCMCIA, SDRAM	BP-176V
	7650	R4S76500B133BG	16	3.0	3.6	133	1	-	-	2	-	4	-	-	HIF, Ether MAC, PCI, PCMCIA, SDRAM	BP-336V
SH3-DSP	7710	HD6417710BPV	16	1.4	1.6	200	1	-	-	4	-	6	7	24	Dual Ether MAC, IPsec, PCMCIA, SDRAM	BP-256HV
	7710	HD6417710FV	16	1.4	1.6	200	1	-	-	4	-	6	7	24	Dual Ether MAC, IPsec, PCMCIA, SDRAM	FP-256GV
	7712	HD6417712BPV	16	1.4	1.6	200	1	-	-	4	-	6	7	24	Dual Ether MAC, PCMCIA, SDRAM	BP-256HV
	7712	HD6417712FV	16	1.4	1.6	200	1	-	-	4	-	6	7	24	Dual Ether MAC, PCMCIA, SDRAM	FP-256GV
	7713	HD6417713BPV	16	1.4	1.6	200	1	-	-	4	-	6	7	24	Ether MAC, PCMCIA, SDRAM	BP-256HV
	7713	HD6417713FV	16	1.4	1.6	200	1	-	-	4	-	6	7	24	Ether MAC, PCMCIA, SDRAM	FP-256GV
SH-4A	7763	R5S77630Y266BGV	16	1.15	1.35	266	1	4	2	3	3	6	5	118	Dual GbE MAC, USB Host & Function, LCDC, PCI, FPU, DDR	BP-449V
	7764	R5S77640N300BGV	16	1.1	1.3	324	1	-	-	3	-	6	3	69	Ether MAC, High-speed USB Host/Function, LCDC, ATAPI, I ² C, SSI, FPU, NAND	BP-404V

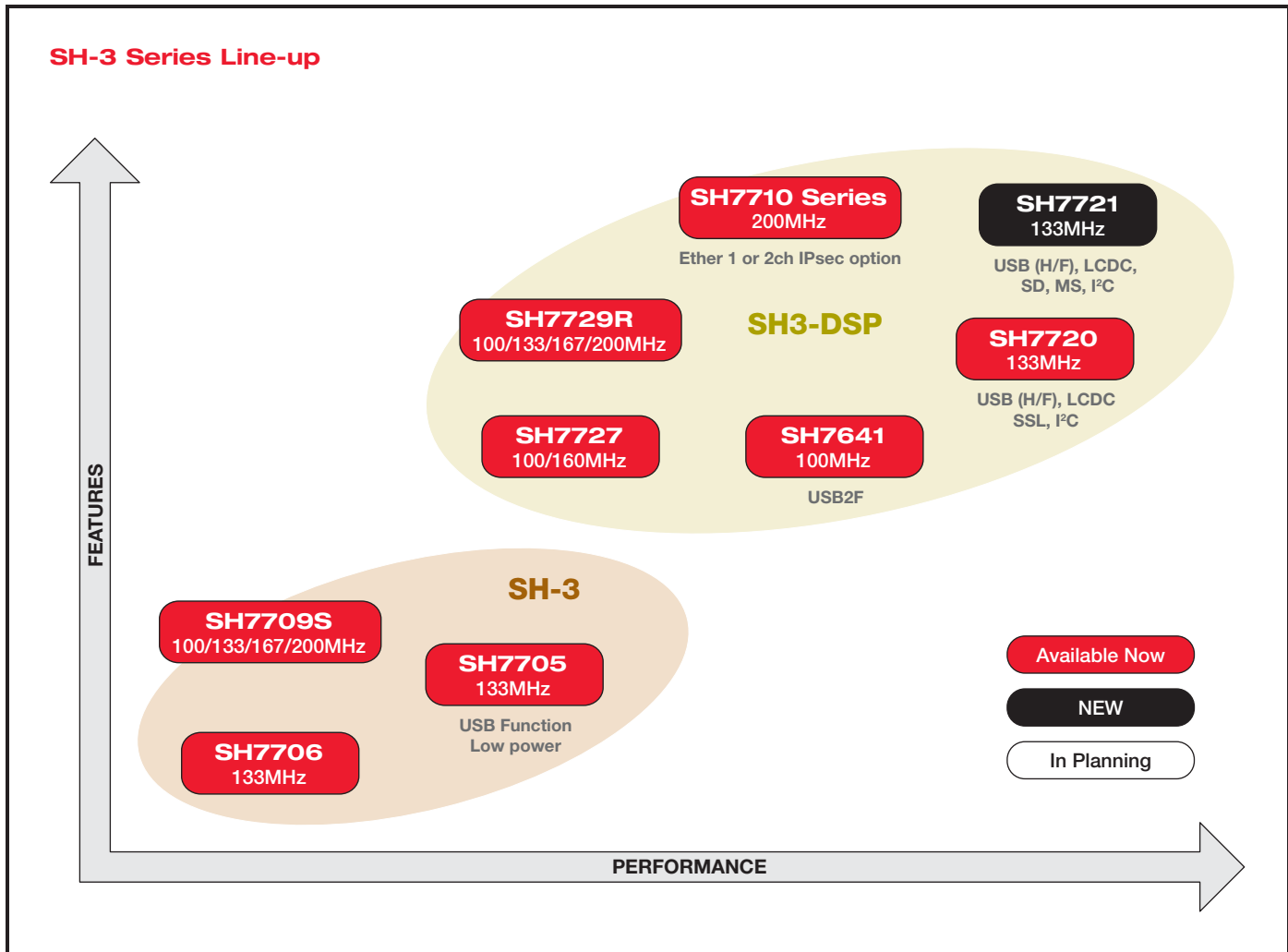

■ SH-3 Features

- Highest MIPS/watt and MIPS/\$ ratings in the industry
- Easy connectivity with built-in peripherals such as USB host/function controllers
- Highly-integrated RISC MPUs in compact micro-BGA and QFP packages reduce board space and system cost
- Flexible bus structure: Four-bus structure allows simultaneous DMA, CPU and DSP access
- Widely supported by third parties and Renesas; product-ready platforms, schematics, software and middleware available
- SH3-DSP devices have on-chip DSP for applications such as signal processing, video streaming, etc.
- On-chip hardware support for debugging
- Clever power management for longer battery life
 - Ultra-low power appliances, boasting a current consumption of just 1mA per MHz (e.g., SH7705)
 - Three power-down modes are available to lower power consumption
 - Clock gearing enables clock to be changed on the fly

■ Applications

Office Appliances:

Laser printers, video printers, scanners, bar code scanners, fax machines, TV conference systems

Industrial:

Postage meters, industrial control terminals, medical equipment

Consumer: Digital still cameras, digital video cameras, Web phones

Network/Communication:

Low-cost Internet appliances, electronic dictionaries, personal organizers, Handheld PCs, PDAs, point-of-sale terminals, IP telephony, mobile phones, multimedia terminals, portable information devices, web cameras, routers, cable modems

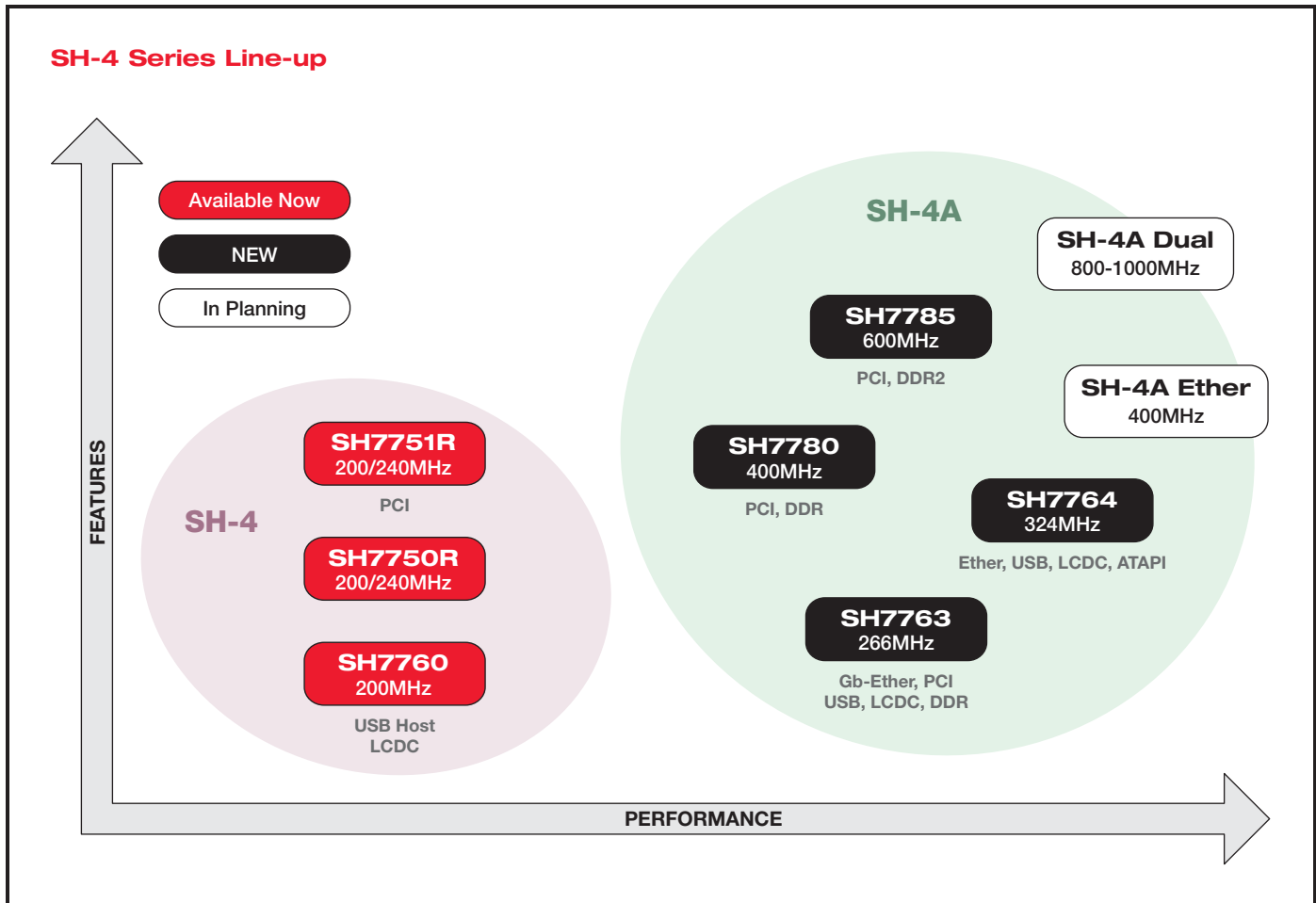

■ Features

- Two-way superscalar support – top performance per MHz
 - Harvard architecture, RISC and FPU instructions executed in parallel
 - Up to 600MHz 32-bit RISC engine @ 1080 MIPS (32-bit registers, 16-bit instructions)
 - Can access four instructions per memory access (64-bit ext. bus)
- Integrated IEEE754-compliant FPU co-processor
 - High-speed single-precision and double-precision operations
 - Can process an impressive seven million polygons per MHz
- Direct connection to SDRAM, DDR-SDRAM, SRAM, Burst ROM, PCMCIA
- Includes DSP/SIMD instruction – true multimedia acceleration
 - FIPR can perform 4-way dot product in a single cycle
 - FTRV can perform a 4-cycle, 4 x 4 matrix-vector multiplication.
- Optimized cache architecture: double size and 4-way associative to reduce cache misses and minimize latency
- Highly-integrated peripherals on device: e.g., SH7763 includes FPU, USB Host and function, built-in LCD controller, Gigabit Ethernet controller, PCI, etc.
- The SH-4 and SH-4A cores feature an advanced power-saving mechanism with built-in power-down modes
- On-chip hardware support for debugging
- Widely supported by third parties and Renesas; product-ready platforms, schematics, software and middleware available
- Investment protection: upward compatibility and long-term product supply and support

■ Applications

Networking/Communications:

Handheld PCs, point-of-sale devices, Internet appliances, VoIP/webphones, home gateways, routers

Computing: High-performance multimedia terminals, digital TVs, set-top boxes, game machines, fingerprint detectors, passport readers

SH-4 Series Selector Guide

Series	Group	Device Number	RAM (Kbytes)	Vcc min	Vcc max	max MHz @ Vcc max	Watchdog Timer	A/D 10-bit resolution	D/A 8-bit resolution	Serial (Sync/Async) DMA Channels	External Interrupts	GPIO	Special Features	Package Code	
SH-4	7750R	HD6417750RBP200V	-	1.35	1.6	200	1	-	-	2	8	5	20	TMU, PCMCIA, FPU, SDRAM	BP-256AV
	7750R	HD6417750RF200V	-	1.35	1.6	200	1	-	-	2	8	5	20	TMU, PCMCIA, FPU, SDRAM	FP-208EV
	7750R	HD6417750RBP240V	-	1.4	1.6	240	1	-	-	2	8	5	20	TMU, PCMCIA, FPU, SDRAM	BP-256AV
	7750R	HD6417750RF240V	-	1.4	1.6	240	1	-	-	2	8	5	20	TMU, PCMCIA, FPU, SDRAM	FP-208EV
	7751R	HD6417751RBP200V	-	1.35	1.6	200	1	-	-	2	8	5	32	TMU, PCMCIA, FPU, PCI, SDRAM	BP-256AV
	7751R	HD6417751RF200V	-	1.35	1.6	200	1	-	-	2	8	5	32	TMU, PCMCIA, FPU, PCI, SDRAM	FP-256GV
	7751R	HD6417751RBP240V	-	1.4	1.6	240	1	-	-	2	8	5	32	TMU, PCMCIA, FPU, PCI, SDRAM	BP-256AV
	7751R	HD6417751RF240V	-	1.4	1.6	240	1	-	-	2	8	5	32	TMU, PCMCIA, FPU, PCI, SDRAM	FP-256GV
	7760	HD6417760BP200ADV	-	1.4	1.6	200	1	4	-	3	8	9	70	USB Host, LCDC, AC97, SSI, PCMCIA, FPU, CAN, SDRAM	BP-256FV
	7760	HD6417760BL200AV	-	1.4	1.6	200	1	4	-	3	8	9	70	USB Host, LCDC, AC97, SSI, PCMCIA, FPU, CAN, SDRAM	BP-256BV
7760	HD6417760BL200ADV	-	1.4	1.6	200	1	4	-	3	8	9	70	USB Host, LCDC, AC97, SSI, PCMCIA, FPU, CAN, SDRAM	BP-256BV	
SH-4A	7780	R8A77800ANBGV	48	1.15	1.35	400	1	-	-	2	12	9	83	CMT, TMU, NAND, PCMCIA, MMC, DDR, PCI, FPU, AC97, SSI	BP-449V
	7780	R8A77800ADBGV	48	1.15	1.35	400	1	-	-	2	12	9	83	CMT, TMU, NAND, PCMCIA, MMC, DDR, PCI, FPU, AC97, SSI	BP-449V
	7781	R8A77810ANBGV	48	1.15	1.35	400	1	-	-	2	12	9	83	CMT, TMU, NAND, PCMCIA, MMC, DDR, PCI, FPU, AC97, SSI, IPsec	BP-449V
	7781	R8A77810AHBG	48	1.15	1.35	400	1	-	-	2	12	9	83	CMT, TMU, NAND, PCMCIA, MMC, DDR, PCI, FPU, AC97, SSI, IPsec	BP-449V
	7785	R8A77850ANBGV	152	1.0	1.2	600	1	-	-	6	12	9	-	TMU, NAND, PCMCIA, MMC, DDR2, PCI, FPU, AC97, SSI, LCDC	FC-BGA436
	7785	R8A77850ADBGV	152	1.0	1.2	600	1	-	-	6	12	9	-	TMU, NAND, PCMCIA, MMC, DDR2, PCI, FPU, AC97, SSI, LCDC	FC-BGA436



SH-Mobile Series Line-up

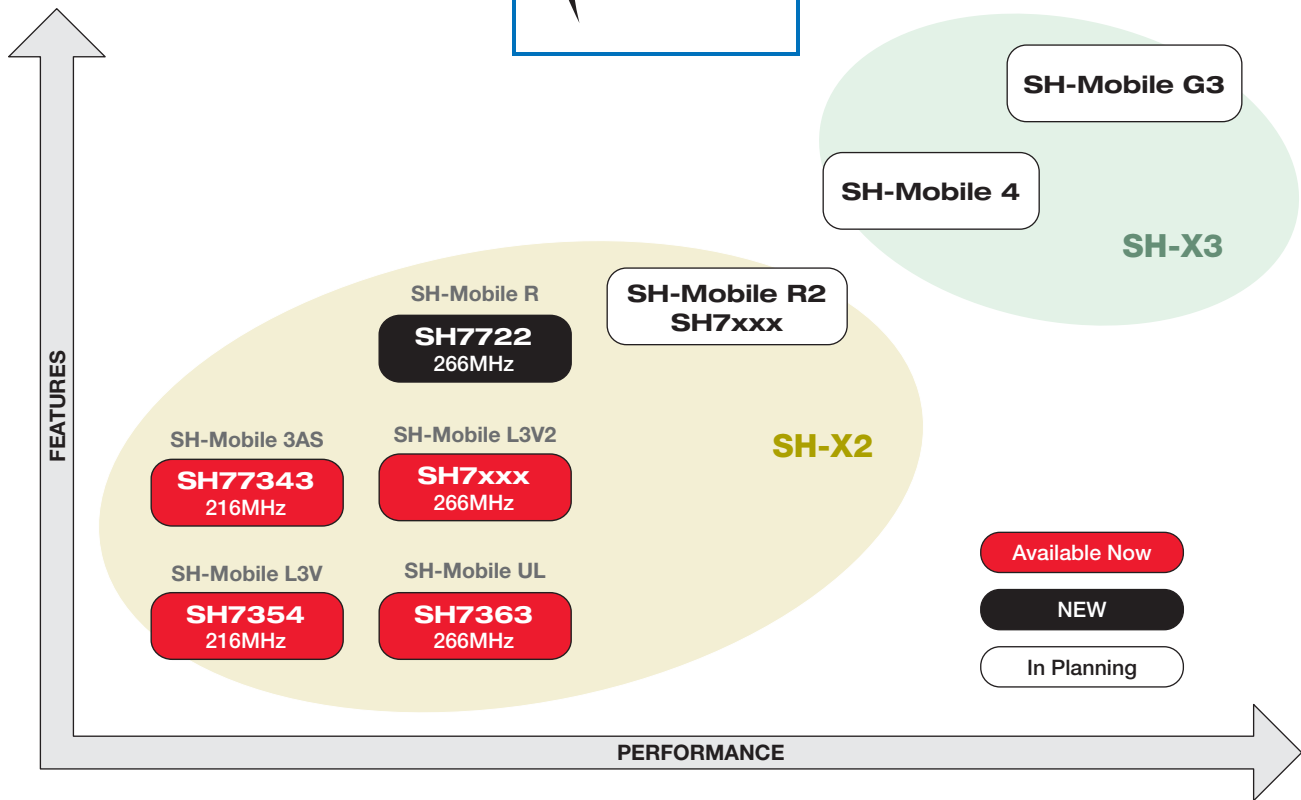

SH-Mobile Series Block Diagram

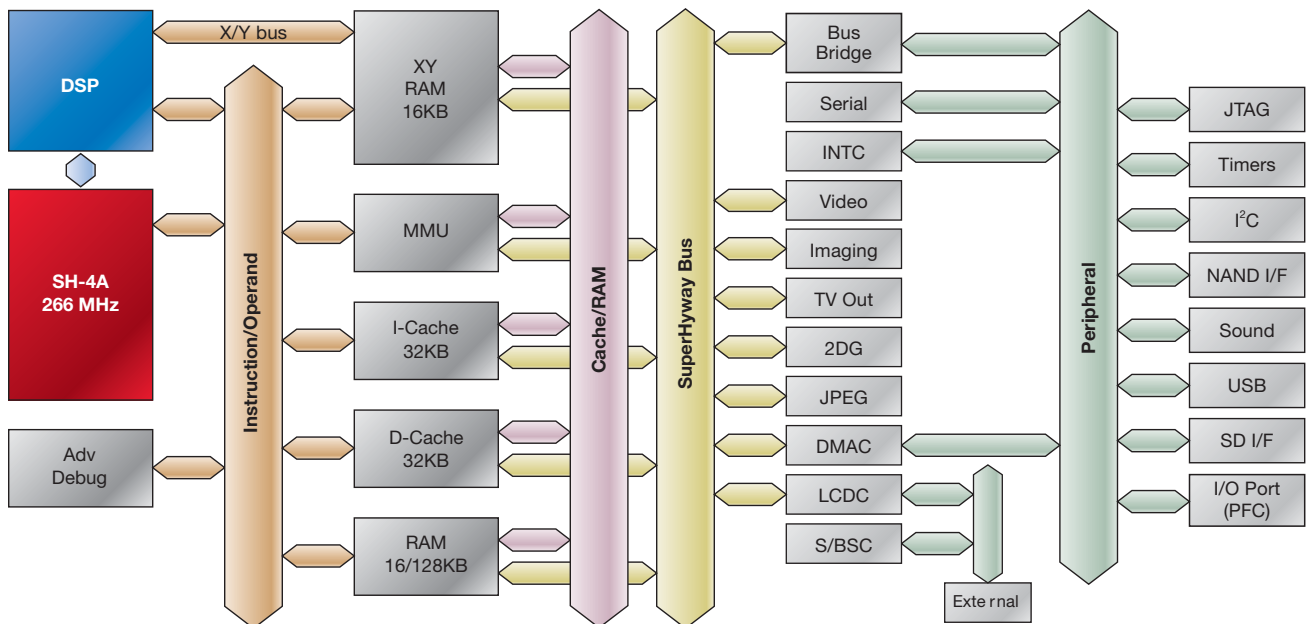

■ Features

- High-performance with low power consumption
 - Superscalar CPU provides ample horsepower at low frequency – 4500 MIPS/W
 - Integral DSP instructions offer flexibility for optimized audio and speech algorithms
- Industry-leading low-power multimedia hardware accelerators
 - H.264, MPEG4, and H.263 video engines with up to D1 resolution offloads CPU, minimizes power consumption, and optimizes visual quality
 - 5Mpixel camera/video input port supports color space conversion, blend, rotate, scale and overlays
 - Realtime JPEG engine speeds up digital imaging operations
 - 2D / 3D graphics engines facilitate smooth user experience
- Up to 24 bpp LCD controller for true color display
- TV output for additional display option
- Integrated sound interface provides rich multimedia experience
- Memory card interface and NAND flash interface offer more expansion options
- Integrated high-speed USB function for PC connectivity

■ Applications

Single-chip multimedia player:

- Handheld digital TV capability
- Multi-format video
- Multi-format audio
- DRM host
- DVB-H, DMB, ISDB-T, etc.

VoIP capability for multimedia phones

Personal navigation

IP camera

■ SH-Mobile Solutions

- Development platform
 - SH-Mobile Solution Engine
- RTOS with board support package
 - Embedded Linux BSP
- Multimedia middleware
 - H.264, MPEG4, H.263 video codecs
 - MP3, WMA, AAC, AAC+ audio codecs
 - G.7xx speech codecs, LEC, AEC
 - Media player
- Network stacks
 - TCP/IP
 - RTP
 - SIP
- GUI software
 - QTopia
 - 2D/3D graphics and imaging libraries
- SH-Mobile Consortium
 - Over 200 companies developing middleware, applications, and system designs based on SH-Mobile devices

SH-Mobile Series Selector Guide

Group	Device Number	SDRAM (Mbytes)				Watchdog Timer	FLCTL	SDHI	LCD Controller	Serial	I ² C	DMA Channels	External Interrupts	GPIO	Special Features	Package Code
		Vcc min	Vcc max	max MHz @ Vcc max												
7343	R8J73437BGZV	16	1.1	1.3	216	1	Y	Y	QVGA 24bpp	7	2	6	9	176	DSP, VPU4, VIO, VOU, JPU, TSIF, SIU, 3DG, USBF, MFI	BP-409V
7354	R8J73540BGZV	16	1.15	1.3	216	1	Y	Y	QVGA 18bpp	3	1	6	6	144	DSP, VPU4, VIO, JPU, TSIF, SIU, MFI	BP-409V
7363	R8J73630BGV R8J73630BGZV	16	1.15	1.3	266	1	Y	Y	QVGA 18bpp	3	1	6	6	100	DSP, VPU5, VIO, VOU, JPU, TSIF, SIU, MFI	BP-409V
7722	R8A77220AC266BGV	-	1.15	1.3	266	1	Y	Y	QVGA 24bpp	6	1	6	9	184	DSP, VPU4, VIO, VOU, JPU, TSIF, SIU, 2DG	BP-409V
	R8A772201AC266BGV	-	1.15	1.3	266	1	Y	Y	QVGA 24bpp	6	1	6	9	184	DSP, VPU4, VIO, VOU, JPU, TSIF, SIU, 2DG, USBF	BP-409V

■ Application Example 1: AC Servo System Configuration Using SH7206 (SH-2 series)

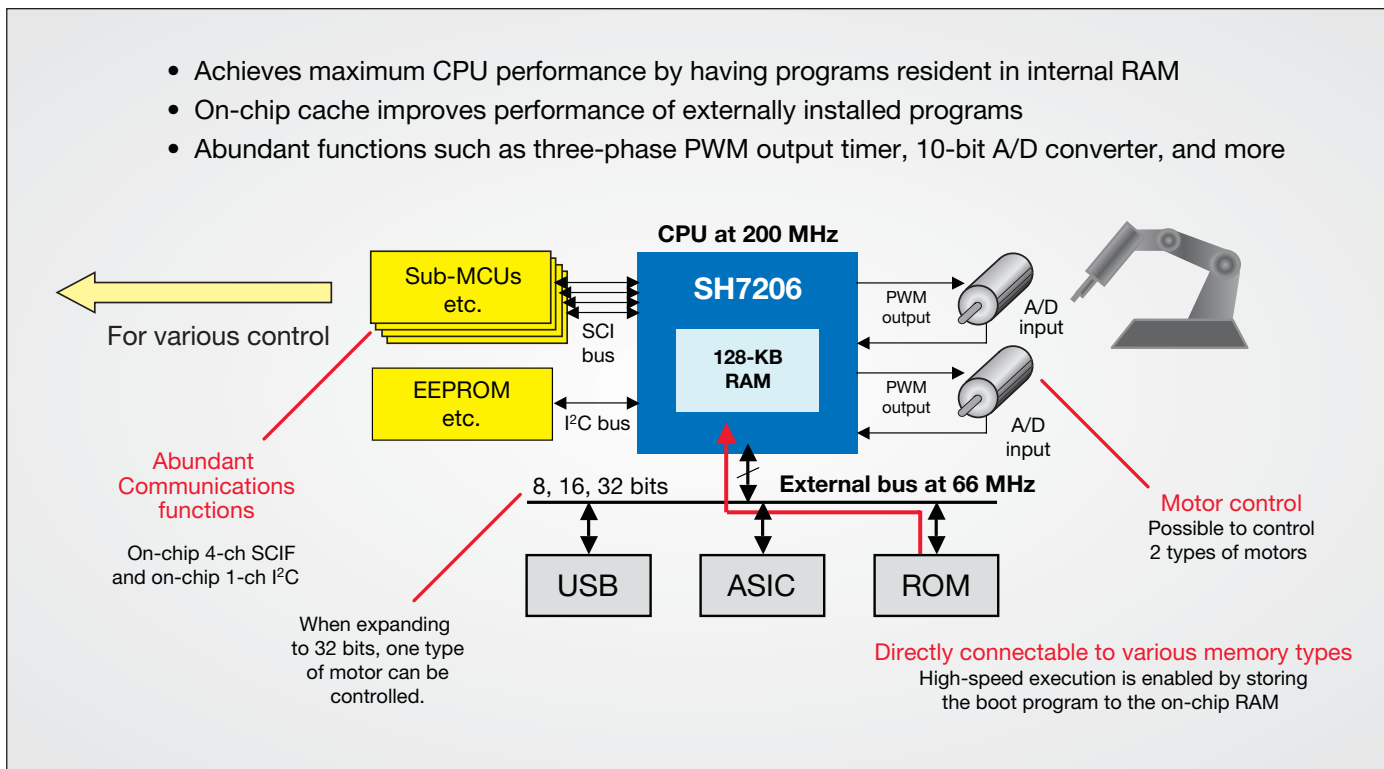

■ Application Example 2: Multimedia/Digital TV Player using SH7722 (SH-Mobile series)

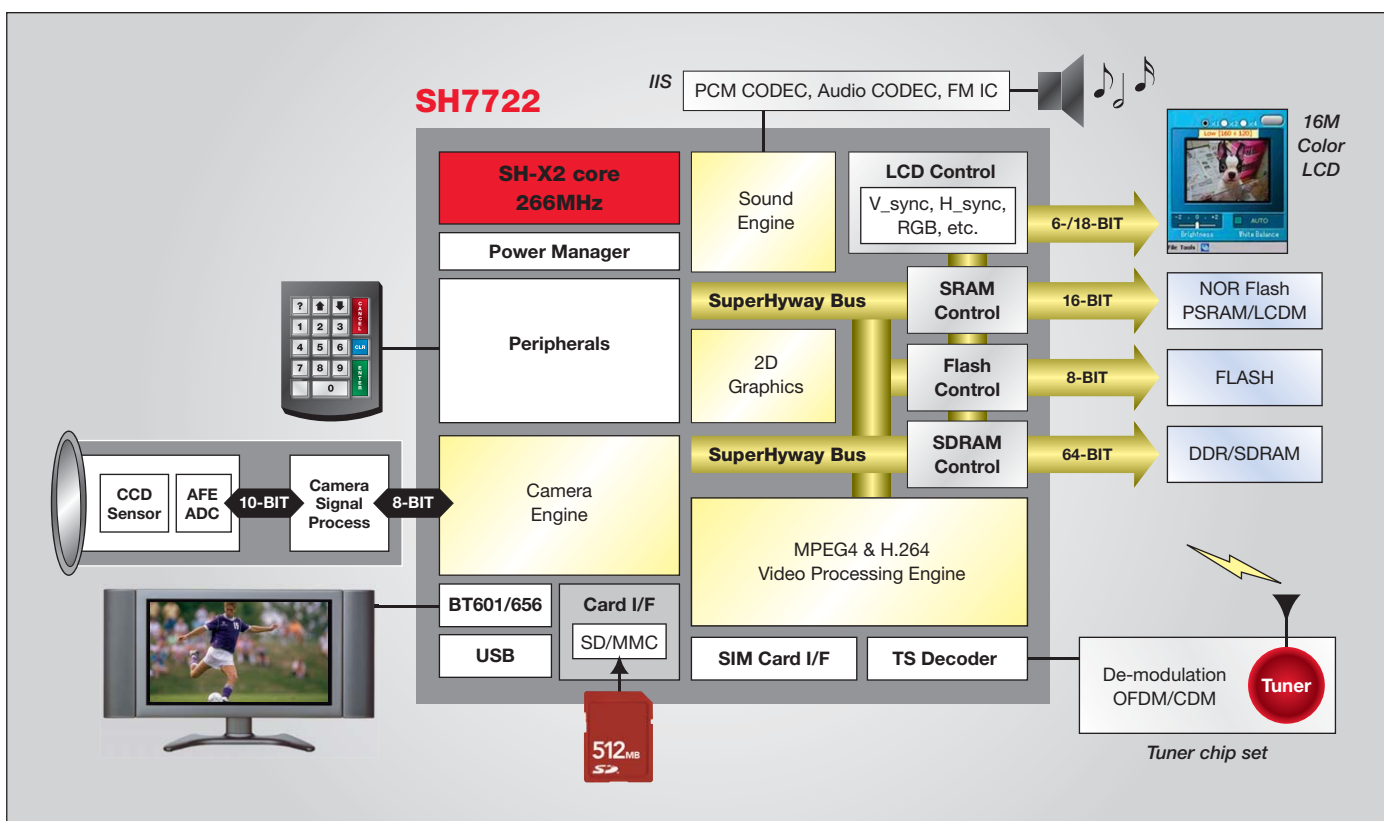

■ Application Example 3: Video VoIP System Using SH7722 (SH-Mobile series)

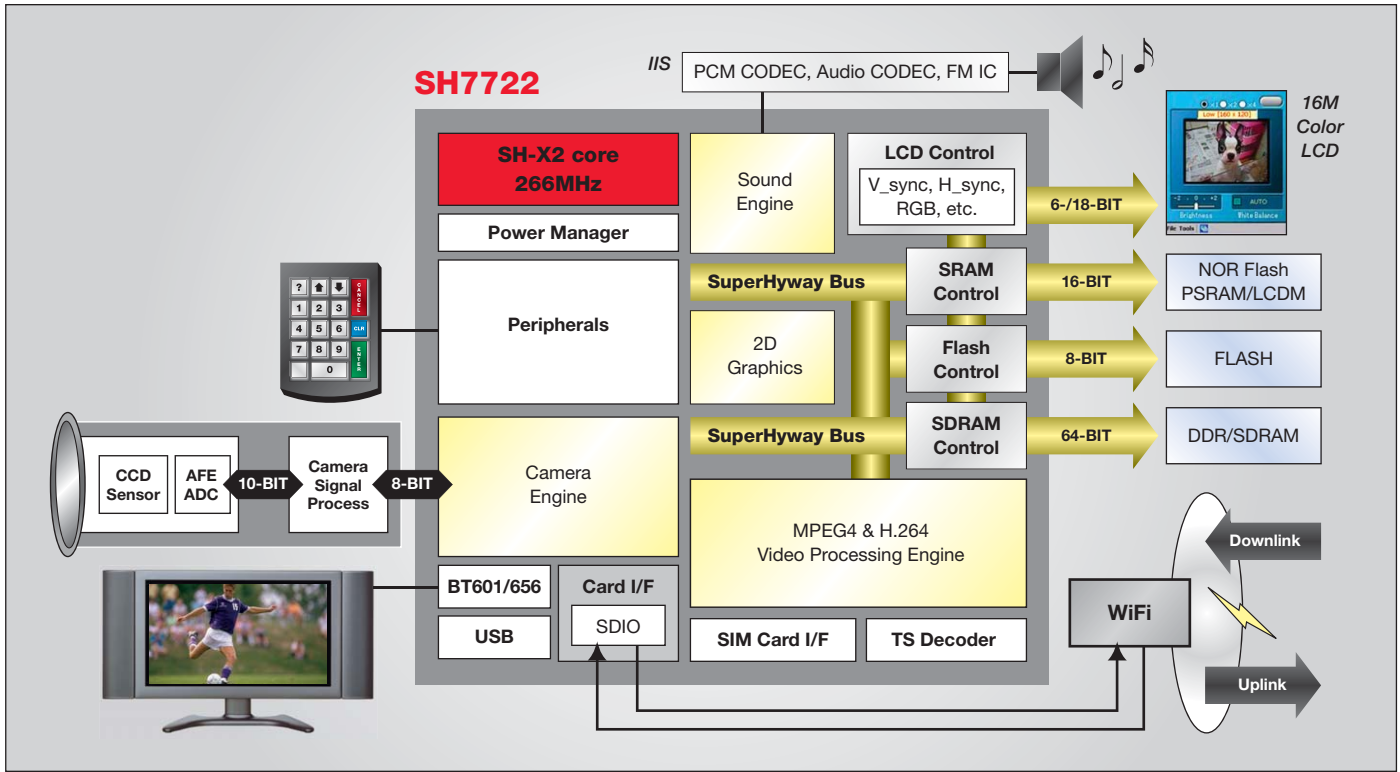

■ Application Example 4: Multimedia Gateway Configuration using SH7763 (SH-4 series)

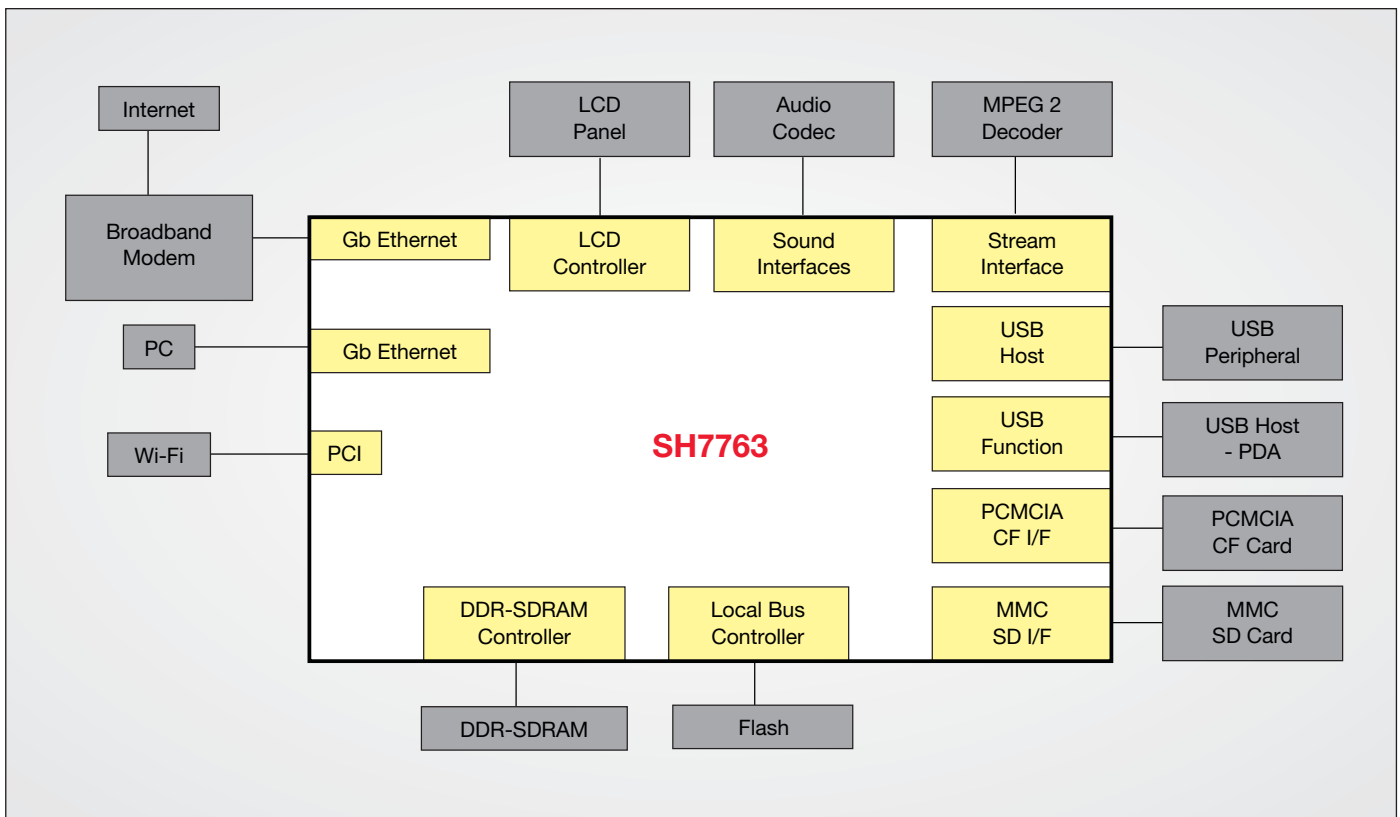

■ Appendix A-1: Architecture of SH-2 and SH2-DSP Series

= SH-DSP only

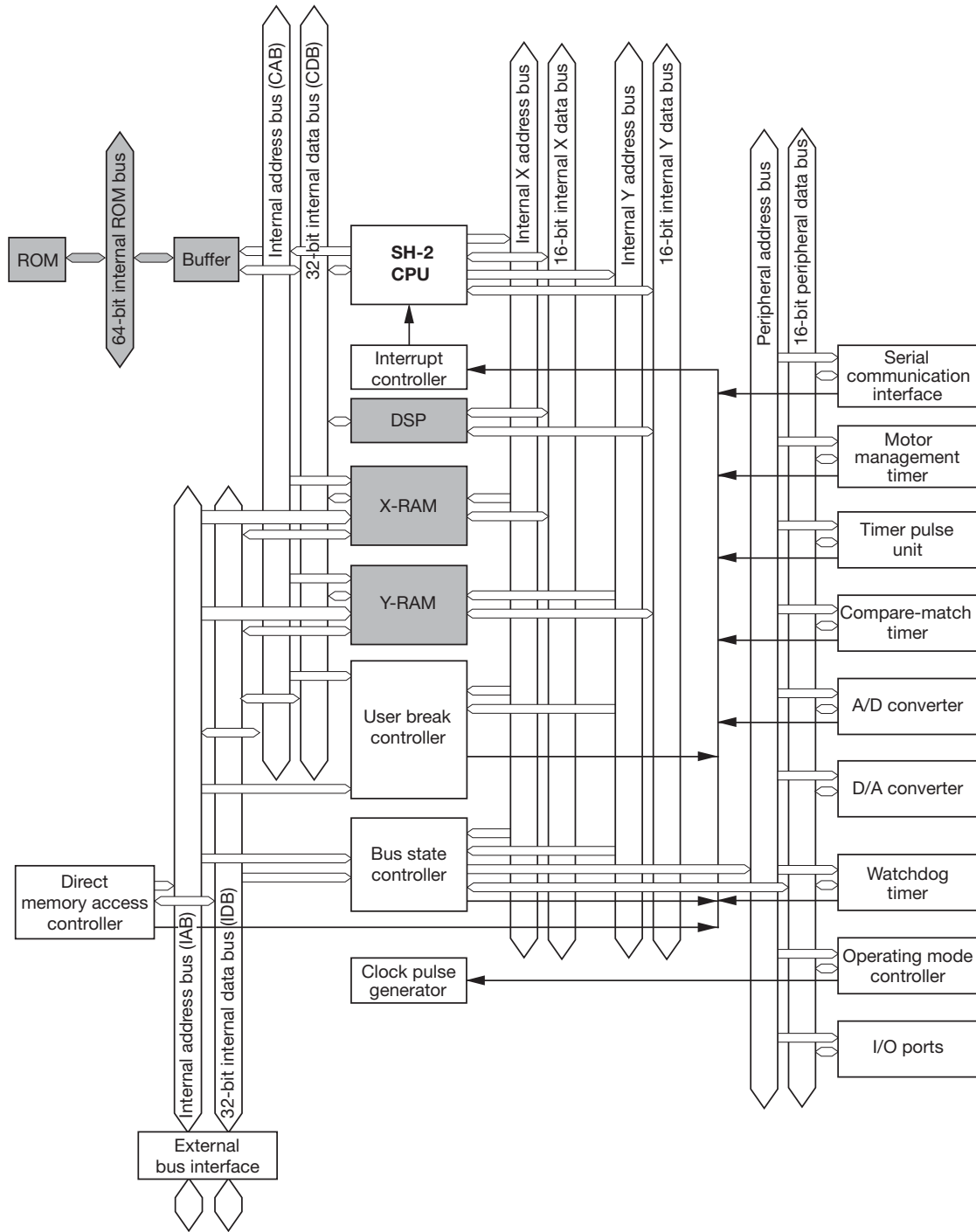

LEGEND:

CPG	Clock Programmable Generator	MTU	Multifunction Timer Pulse Unit	TIM 2	8-Bit Timer 2
ADC	Analog to Digital Converter	CMT	Compare Match Timer	HCAN	Car Automotive Network
DAC	Digital to Analog Converter	PWM	Pulse Width Modulator	HCAN2	Car Automotive Network
TPU	16-Bit Timer Pulse Unit	ATU	Advanced Timer Unit	SCI	Serial Communication Interface
WDT	WatchDog Timer	ATU-II	Advanced Timer Unit-II	UDI	User Debug Interface
MMT	Motor Management Timer	APC	Advanced Pulse Controller	DTC	Data Transfer Controller
				PFC	Pin Function Controller

Appendix A-2: Architecture of SH-2A Series

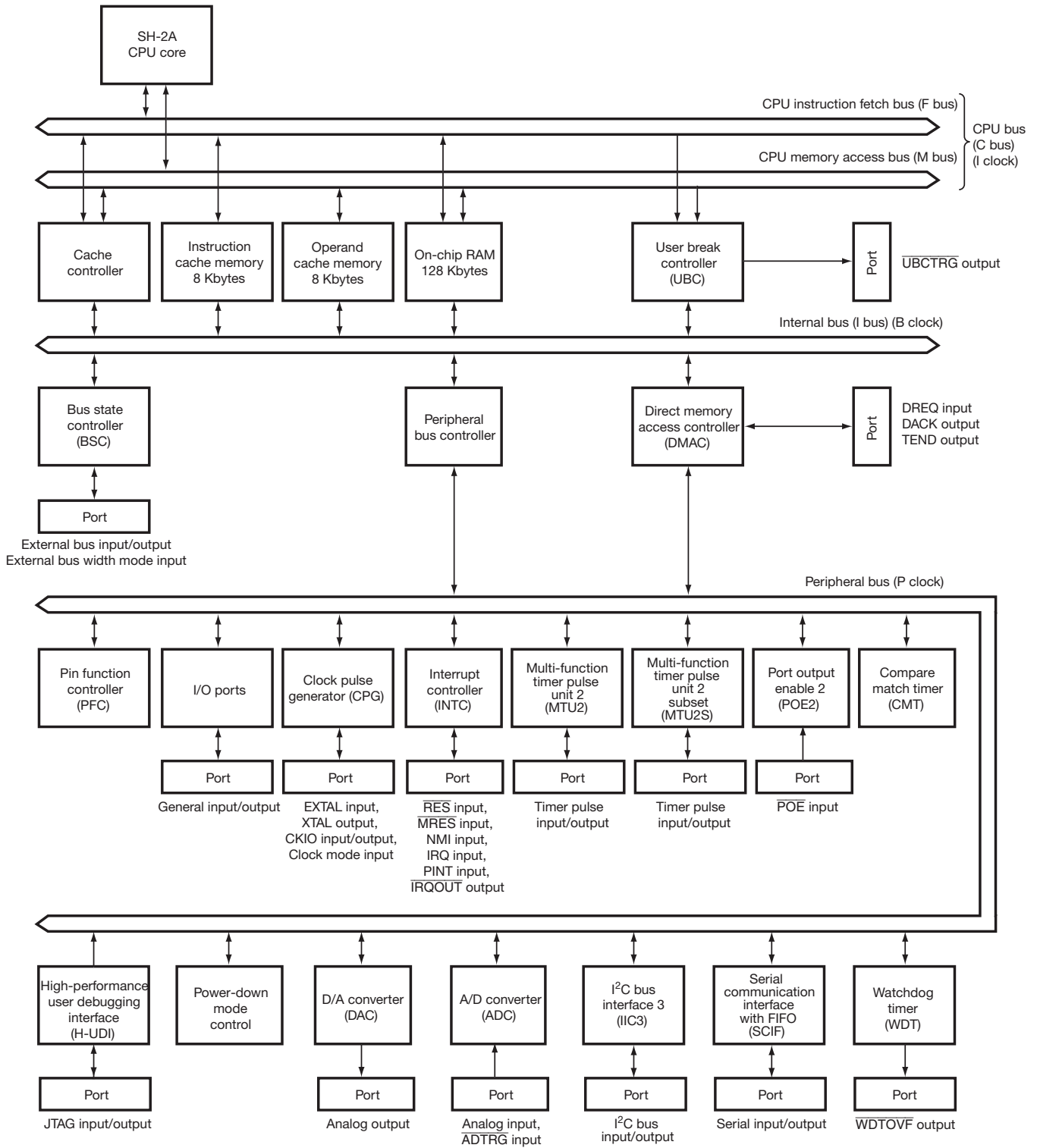

Appendix A-3: Architecture of SH-3, SH3-DSP, and SH-4 Series

SH-3, SH3-DSP Architecture

 = SH3-DSP only

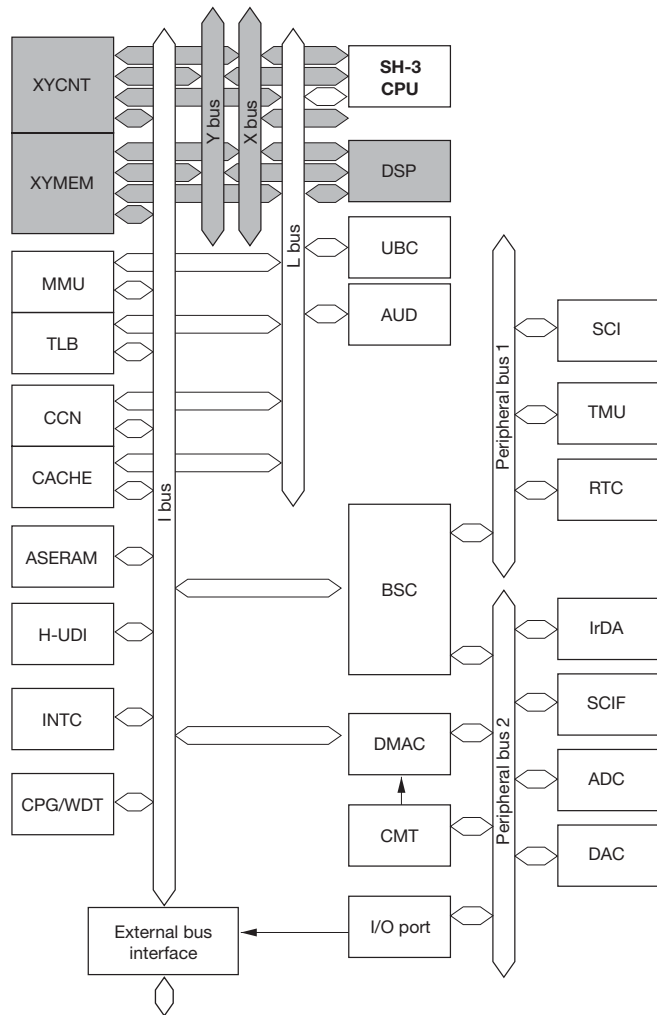

LEGEND:

- ADC: A/D converter
- ASERAM: ASE memory
- AUD: Advanced user debugger
- BSC: Bus state controller
- CACHE: Cache memory
- CCN: Cache memory controller
- CMT: Compare match timer
- CPG/WDT: Clock pulse generator/watchdog timer
- CPU: Central processing unit
- DAC: D/A converter
- DMAC: Direct memory access controller
- DSP: Digital signal processor
- INTC: Interrupt controller
- IrDA: Serial communication interface (with IRDA)
- MMU: Memory management unit
- RTC: Realtime clock
- SCI: Serial communication interface (with smart card interface)
- SCIF: Serial communication interface (with FIFO)
- TLB: Translation look-aside buffer
- TMU: Timer unit
- UBC: User break controller
- UDI: User debugging interface
- XYCNT: X/Y memory controller
- XYMEM: X/Y memory

SH-4 Architecture

 = SH7751R only

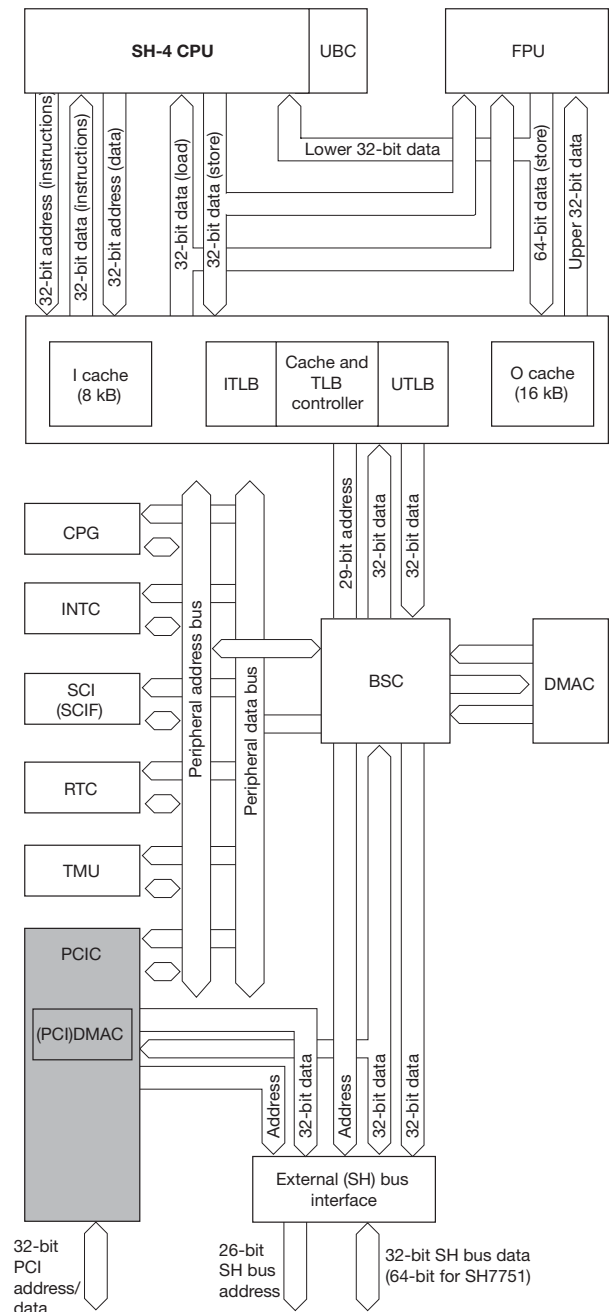

LEGEND:

- BSC: Bus state controller
- CPG: Clock pulse generator
- DMAC: Direct memory access controller
- FPU: Floating-point unit
- INTC: Interrupt controller
- ITLB: Instruction TLB (translation lookaside buffer)
- UTLB: Unified TLB (translation lookaside buffer)
- RTC: Realtime clock
- SCI: Serial communication interface
- SCIF: Serial communication interface with FIFO
- TMU: Timer unit
- UBC: User break controller
- PCIC: PCI bus controller

■ Appendix A-4: Architecture of SH-4A Series

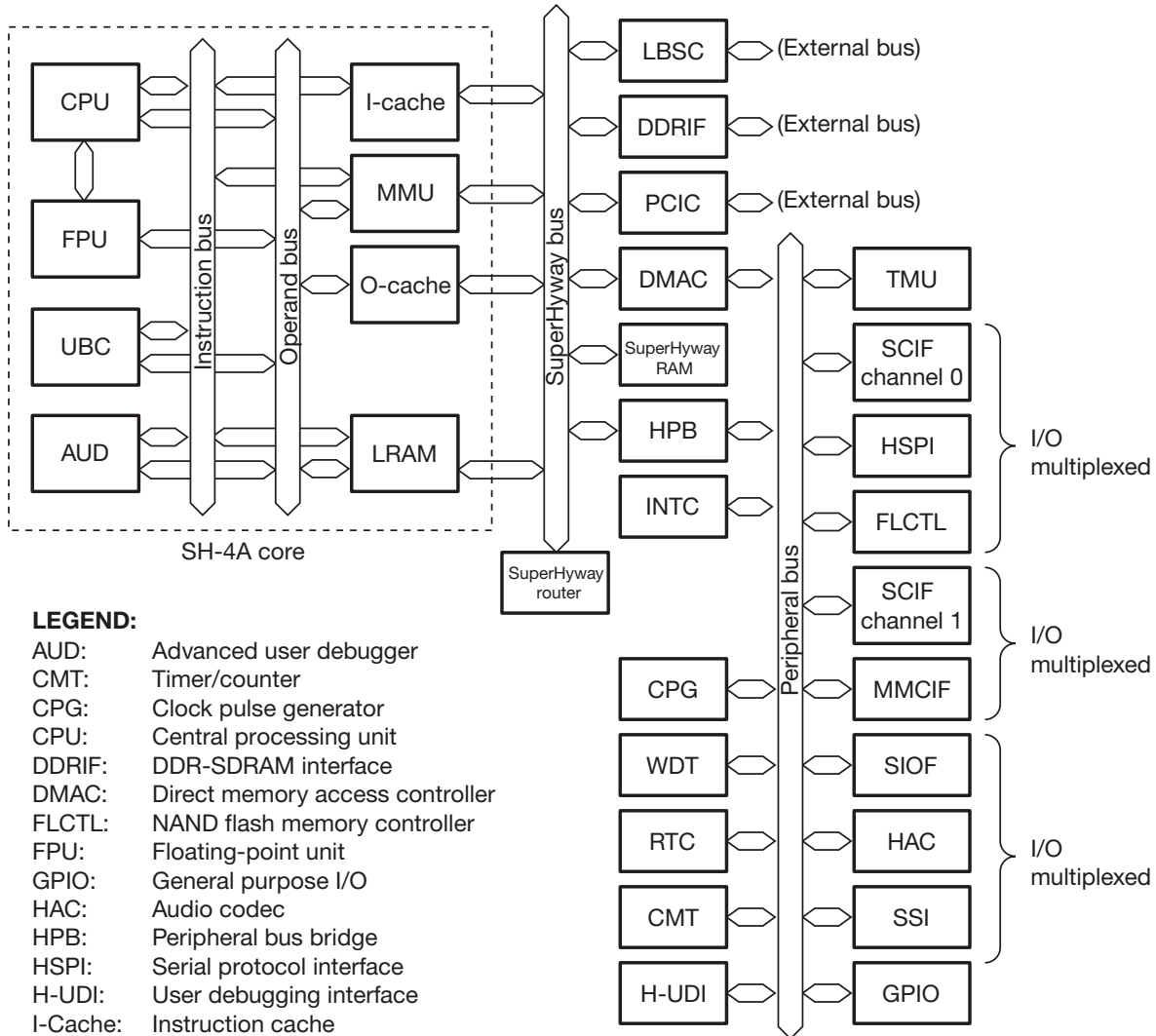

LEGEND:

- AUD: Advanced user debugger
- CMT: Timer/counter
- CPG: Clock pulse generator
- CPU: Central processing unit
- DDRIF: DDR-SDRAM interface
- DMAC: Direct memory access controller
- FLCTL: NAND flash memory controller
- FPU: Floating-point unit
- GPIO: General purpose I/O
- HAC: Audio codec
- HPB: Peripheral bus bridge
- HSPI: Serial protocol interface
- H-UDI: User debugging interface
- I-Cache: Instruction cache
- INTC: Interrupt controller
- LBSC: Local bus state controller
- LRAM: L memory
- MMCIF: Multimedia card interface
- MMU: Memory management unit
- O-Cache: Operand (data) cache
- PCIC: PCI controller
- RTC: Realtime clock

- SCIF: Serial communication interface with FIFO
- SIOF: Serial I/O with FIFO
- SSI: Serial sound interface
- SuperHyway RAM: SuperHyway memory
- TMU: Timer unit
- UBC: User break controller
- WDT: Watchdog timer

■ Appendix B-1: Nomenclature of SuperH Part Numbers (1 of 2)

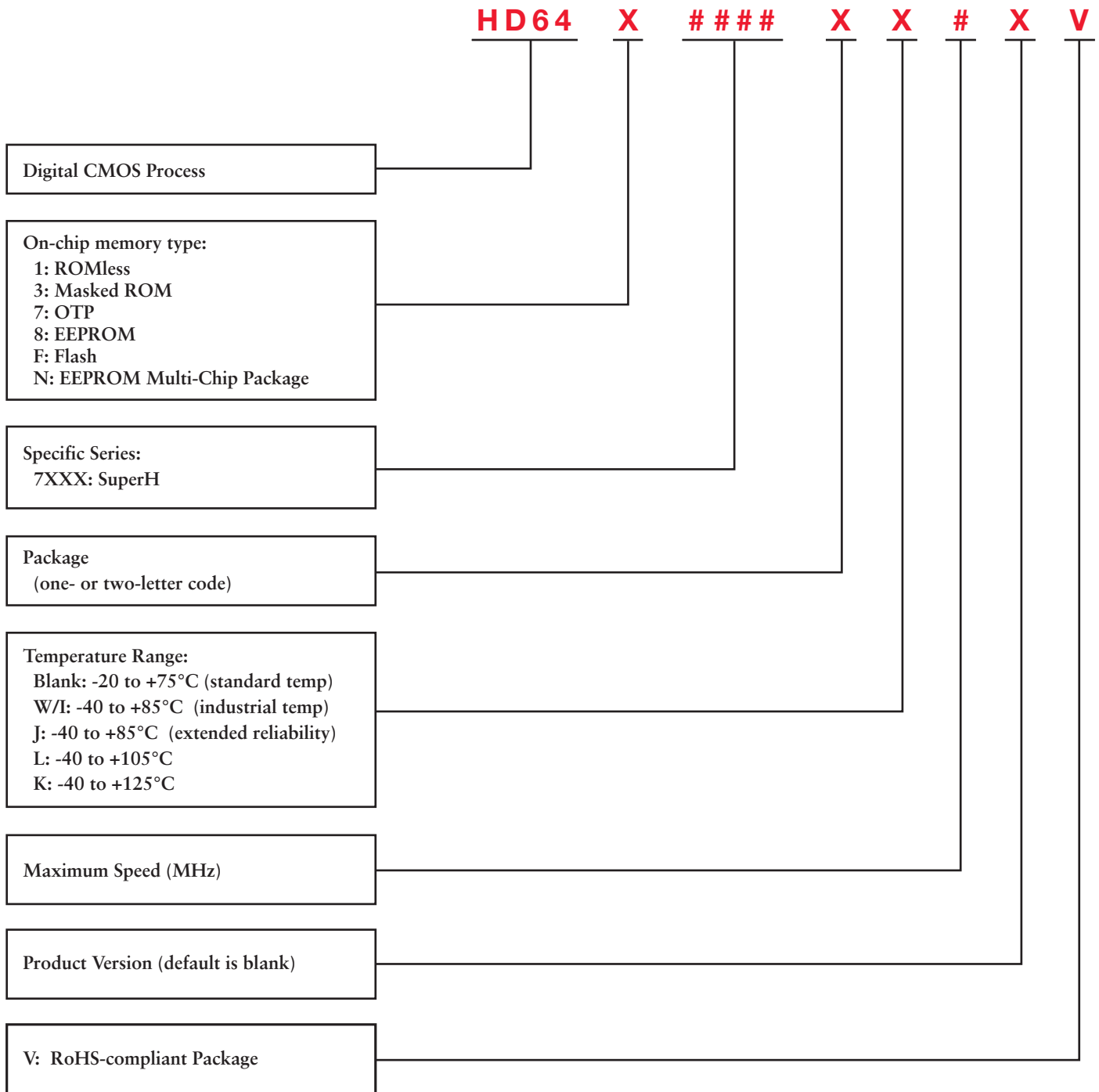

Appendices

■ Appendix B-2: Nomenclature of SuperH Part Numbers (2 of 2)

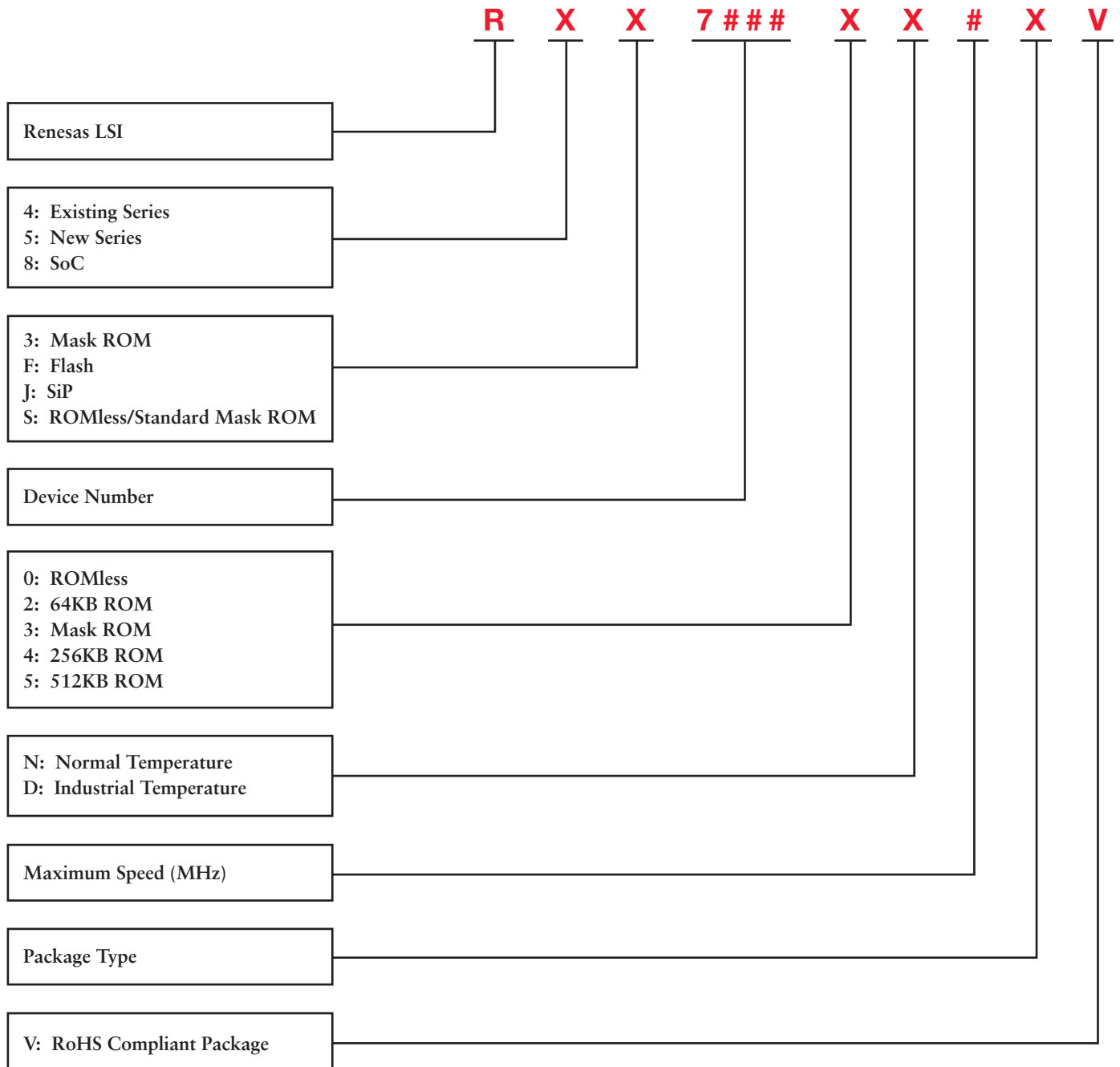

■ Appendix C: Abbreviations

2DG	2D Graphics
3DG	3D Graphics
AC97	AC '97 Audio Interface
AUD	Advanced User Debug
BSC	Bus State Controller
CAN	Controller Area Network
CMT	Compare Match Timer
DDR	Double Data Rate SDRAM Controller
DDR2	Double Data Rate 2 SDRAM Controller
DMA	Direct Memory Access
DSP	Digital Signal Processor
DTC	Data Transfer Controller
Ether MAC	Ethernet Media Access Control
Ether PHY	Ethernet Physical Layer
FLCTL	NAND Flash Controller
FPU	Floating Point Unit
GbE MAC	Gigabit Ethernet Media Access Control
HIF	Host Interface
I ² C	Inter IC Bus
IPsec	Internet Protocol Security
JPU	JPEG Processing Unit
LCDC	LCD Controller
MAC	Multiply Accumulate Instruction

MFI	Multi-Function Interface
MMC	Multimedia Card
MMT	Motor Management Timer
MTU	Multi-function Timer pulse Unit
MTU2	Multi-function Timer pulse Unit 2
MTU2S	Multi-function Timer pulse Unit 2S
NAND	NAND Flash Controller
PCI	PCI Bus Interface
PCMCIA	PCMCIA Bus Interface
SDHI	Secure Digital Host Interface
SDRAM	SDRAM Controller
SIU	Sound Interface Unit
SSI	Serial Sound Interface
SSL	Secure Socket Layer
STIF	Stream Interface
TMU	Timer Unit
TPU	Timer Pulse Unit
TSIF	Transport Stream Interface
USB Function	Universal Serial Bus Function Interface
USB Host	Universal Serial Bus Host Interface
VIO	Video Input/Output
VOU	Video Output Unit
VPU	Video Processing Unit

■ Appendix D: Package Specifications

Type	Renesas Code	Previous Code	Pin Count	Nominal Body Dimensions (mm)	Lead Pitch (mm)	Thickness (mm)
QFP (Quad Flat Package)	PRQP0064GB-A	FP-64A	64	14 x 14	0.80	3.05
LQFP (Low-Profile QFP)	PLQP0048JA-A	FP-48F	48	10 x 10	0.65	1.70
	PLQP0064KB-A	FP-64K	64	10 x 10	0.50	1.70
	PLQP0080JA-A	FP-80W	80	14 x 14	0.65	1.70
	PLQP0100KB-A	FP-100U	100	14 x 14	0.50	1.70
	PLQP0112JA-A	FP-112E	112	20 x 20	0.65	1.70
	PLQP0144KA-A	FP-144L	144	20 x 20	0.50	1.70
	PLQP0176KC-A	FP-176	176	24 x 24	0.50	1.70
	PLQP0176KD-A	FP-176CV	176	24 x 24	0.50	1.70
	PLQP0176KB-A	FP-176E	176	24 x 24	0.50	1.70
	PLQP0176KB-A	FP-176EV	176	24 x 24	0.50	1.70
	PLQP0208KA-A	FP-208C	208	28 x 28	0.80	1.70
	PLQP0208KA-A	FP-208CV	208	28 x 28	0.80	1.70
HQFP (Heat-Sinked QFP)	PRQP0208KE-B	FP-208EV	208	28 x 28	0.50	3.65
	PRQP0256LA-B	FP-256GV	256	28 x 28	0.40	3.95
TQFP (Thin QFP)	PTQP0100KA-A	TFP-100B	100	14 x 14	0.50	1.20
BGA (Ball Grid Array)	PLBG0256GB-A	BP-256BV	256	17 x 17	0.80	1.70
	PRBG0256DE-A	BP-256V	256	27 x 27	1.27	2.50
FBGA (Fine-Pitch BGA)	PLBG0281KE-A	BP-281V	281	9 x 11	0.50	1.40
	TBD	BP-409V	409	12 x 12	0.50	1.40
	PRBG0436GA-A	BP-436V	436	19 x 19	0.80	TBD
	TBD	TBD	449	13 x 13	0.50	TBD
	PRBG0449GA-A	BP-449V	449	21 x 21	0.80	2.00
LFBGA (Low-Profile Fine-Pitch BGA)	PLBG0176GA-A	BP-176V	176	13 x 13	0.80	1.40
	PLBG0240JA-A	BP-240A	240	13 x 13	0.65	1.40
	PLBG0240JA-A	BP-240AV	240	13 x 13	0.65	1.40
	PLBG0256KA-A	BP-256CV	256	11 x 11	0.50	1.40
	PLBG0256FA-A	BP-256FV	256	21 x 21	1.00	1.70
	PLBG0256GA-A	BP-256HV	256	17 x 17	0.80	1.40
	PLBG0336GA	BP-336V	336	17 x 17	0.80	1.40

Order SuperH Family Products Online Quickly and Hassle-free

Users can order SuperH devices and development tools online with just a few clicks on Renesas' website.

Here's how:

1

From the Renesas website, in the Part Number search, enter the Series name (example: SH-4A)

2

Locate the required part number and click on the "Buy Now" button

3

Purchasing information includes pricing and availability for MCU and related tools

Buy Now	1000 Piece Budgetary Price	Docu	Family	Series	Group	Part No.	ROM	RAM	ROM Type	Operating Frequency	Status	Remarks	PKG Code	Part No.
<input type="checkbox"/>	call	PDF	SuperH R5C engine Family	SH7125	SH7125	R5F71252D50FA	64K	8K	Flash memory	50MHz(4.5 to 5.5V)	-	-	PRQP0064GB-A (P-84A)	R5F71252D50FA
<input type="checkbox"/>	call	PDF	SuperH R5C engine Family	SH7125	SH7125	R5F71252D50FP	64K	8K	Flash memory	50MHz(4.5 to 5.5V)	-	-	PRQP0064GB-A (P-54B)	R5F71252D50FP
<input type="checkbox"/>	call	PDF	SuperH R5C engine Family	SH7125	SH7125	R5F71252N50FA	64K	8K	Flash memory	50MHz(4.5 to 5.5V)	-	-	PRQP0064GB-A	R5F71252N50FA

Orderable Parts Number(s)	Package Description	Compliance (RoHS compliant)	1000 Piece Budgetary Price	Request Pricing	Distributor Stock	Distributor Name	Distributor Region	Last Updated Date	Distributor Purchase
DF71252D50FAV	PRQP0064GB-A	YES	call	YES	10	DIGKEY CORPORATION	US	MAR.17.07	Stock

Renesas Interactive – Your Online Environment for Semiconductor Device Research, Evaluation and Application

Renesas Interactive is a valuable FREE online evaluation service that lets you work at your own pace, whenever it is most convenient to do so.

- Take an online interactive training course and learn about the details of Renesas MCU product architectures and peripheral functions, as well as hardware and software development tools.

- Access actual hardware, software and tools in the Virtual Lab Development Environment and take weeks off your MCU assessment, evaluation and setup process.

- Watch live or archived webcasts and find out about new Renesas technology, products and services.



Renesas Technology

www.america.renesas.com

© 2007 Renesas Technology America, Inc. Renesas Technology America, Inc. is a wholly owned subsidiary of Renesas Technology Corp. SuperH and H8 are registered trademarks of Renesas Technology Corp. M16C is a trademark of Renesas Technology Corp. All other trademarks are the property of their respective holders. The information supplied by Renesas Technology America, Inc. is believed to be accurate and reliable, but in no event shall Renesas Technology America, Inc. be liable for any damages whatsoever arising out of the use or inability to use the information or any errors that may appear in this publication. The information is provided as is without any warranties of any kind, either express or implied. Renesas Technology America, Inc. reserves the right, without notice, to make changes to the information or to the design and specifications of its hardware and/or software products. Products subject to availability. Printed in U.S.A.



Printed on Recycled Paper 0407/10K/VIP/PF/SP Order Number: REU01B0019-0701